

# Pumps

---

*Reference Guide*

---





# PUMPS

*Reference Guide*

# TABLE OF CONTENTS

INTRODUCTION.....	1
CHAPTER 1: CLASSIFICATION OF PUMPS .....	3
Kinetic Pumps.....	5
<i>Centrifugal Pumps</i> .....	6
<i>Turbine Pumps (Regenerative)</i> .....	9
<i>Special Pumps</i> .....	10
Positive Displacement Pumps .....	15
<i>Rotary Pumps</i> .....	15
<i>Reciprocating Pumps</i> .....	23
<i>Blow Case Pump</i> .....	26
Open Screw Pump .....	26
CHAPTER 2: CENTRIFUGAL PUMPS:	
PRINCIPLES, COMPONENTS, PERFORMANCE .....	29
Operating Principles.....	29
Centrifugal Pump Classifications and Sub-divisions .....	34
Centrifugal Pump Components.....	35
<i>Casing</i> .....	35
<i>Impellers</i> .....	36
<i>Wearing Rings</i> .....	44
<i>Shafts and Shaft Sleeves</i> .....	46
<i>Stuffing Box</i> .....	49
<i>Mechanical Seals</i> .....	49

<b>TABLE OF CONTENTS</b>
--------------------------

<i>Bearings</i> .....	57
Centrifugal Pump Performance .....	59
<i>Pump Rating Curves</i> .....	59
<i>Pump System Curves</i> .....	62
Centrifugal Pump Applications .....	76
CHAPTER 3: ROTARY PUMPS:	
PRINCIPLES, COMPONENTS, PERFORMANCE .....	79
Operating Principles .....	80
Components of a Rotary Pump .....	80
<i>Pumping Chamber</i> .....	81
<i>Body</i> .....	81
<i>Endplates</i> .....	81
<i>Rotating Assembly</i> .....	81
<i>Seals</i> .....	81
<i>Bearings</i> .....	82
<i>Timing Gears</i> .....	82
<i>Relief Valve</i> .....	82
Rotary Pump Performance .....	83
Rotary Pump Applications .....	91
CHAPTER 4: RECIPROCATING PUMPS:	
PRINCIPLES, COMPONENTS, PERFORMANCE .....	93
Operating Principles .....	93
Components of a Power Pump .....	97

**TABLE OF CONTENTS**

*Liquid End* ..... 97  
*Power End* ..... 99  
Reciprocating Pump Performance ..... 102  
*Main Terms*..... 102  
Reciprocating Pump Applications ..... 108

CHAPTER 5: TIPS: INSTALLATION, OPERATION AND PROBLEM

TRUBLESHOOTING OF PUMPS ..... 111  
Alignment of Shafts ..... 111  
*Couplings* ..... 111  
*Belts and Sheaves*..... 115  
Water Hammer ..... 118  
Minimum Flow Limitation in Centrifugal Pumps ..... 120  
Troubleshooting Pump Problems..... 121  
*Centrifugal Pump*..... 121  
*Rotary Pump* ..... 124  
*Reciprocating Pump* ..... 126

APPENDIX ..... 131

GLOSSARY OF TERMS ..... 135

BIBLIOGRAPHY ..... 143

INDEX ..... 145

ENERGY SERVICES FIELD OFFICES ..... 147

**LIST OF FIGURES**

1. Classification of Pumps .....	4
2. Approximate Upper Performance Limits of Pump Types .....	5
3. Centrifugal Pump .....	6
4. Radial Flow .....	7
5. Mixed Flow .....	8
6. Axial Flow .....	8
7. Turbine Pump .....	9
8. Viscous Drag Pump .....	10
9. Screw Centrifugal Pump .....	12
10. Rotating Casing Pump .....	12
11. Vortex Pump .....	14
12. Sliding Vane Pump .....	16
13. Axial Piston Pump .....	17
14. Flexible Tube Pump .....	18
15. Single Lobe Pump .....	19
16. External Gear Pump .....	19
17. Circumferential Piston Pump .....	20
18. Single Screw Pump (Progressive Cavity) .....	21
19. Screw and Wheel Pump .....	22
20. Two Screw Pump .....	22
21. Horizontal Double Acting Piston Power Pump .....	25
22. Diaphragm Pump .....	25
23. Blow Case Pump .....	27
24. Conventional Screw Pump .....	27
25. Liquid Flow Direction .....	30
26. Typical Centrifugal Pump Casing .....	32

**LIST OF FIGURES (cont'd.)**

27. Volute Casing .....	33
28. Diffusion Vane Casing .....	33
29. Axially Split Casing .....	36
30. Radially Split Casing .....	37
31. Open Impeller .....	38
32. Semi-open Impeller.....	39
33. Enclosed Impeller.....	40
34. Impeller Profile vs. Specific Speed .....	43
35. Flat Type Wearing Ring .....	44
36. "L" Type Wearing Ring .....	45
37. Double Labyrinth Type Wearing Ring .....	45
38. Stuffing Box Sleeve .....	48
39. Conventional Stuffing Box .....	48
40. Single Internal Seal .....	51
41. Single External Seal.....	52
42. Double Seal.....	53
43. Unbalanced Seal.....	54
44. Balanced Seal .....	55
45. Head-Capacity Curve.....	58
46. Brake Horsepower-Capacity Curve .....	60
47. Efficiency-Capacity Curve.....	61
48. NPSH-Capacity Curve.....	63
49. Overall Rating Curves .....	63
50. Simple Pump System.....	64
51. System Curve of a Simple Pump System .....	65
52. Simple Pump System with a Difference in Elevation.....	65



**LIST OF FIGURES (cont'd.)**

53. System Curve of a Simple Pump System with an Elevation Difference .....	66
54. Simple Pump System With a Difference in Elevation and Pressure .....	67
55. System Curve of a Simple Pump System with a Difference in Elevation and Pressure.....	68
56. System Curve .....	68
57. System Curve Indicating Required Pump Flow .....	69
58. Pump Curve Superimposed over System Curve .....	70
59. Effect of Variable Friction Loss .....	71
60. Effect of Varying Pump Head.....	71
61. Effect of Viscosity Increase.....	75
62. External Gear Pump .....	83
63. Slippage Areas .....	84
64. Relationships of Performance Terms .....	85
65. Pump Speed/Viscosity Relationship.....	86
66. Pump Performance at Different Speeds with Viscosity Constant.....	88
67. Effect of Viscosity Increase on Horsepower .....	90
68. Rotary Pump Performance.....	91
69. Liquid End of a Reciprocating Pump During the Suction Stroke.....	94
70. Liquid End of a Reciprocating Pump During the Discharge Stroke.....	95
71. Double-Acting Liquid End .....	97
72. Liquid End of a Horizontal Power Pump.....	98
73. Types of Check Valves .....	100

**LIST OF FIGURES & TABLES**

74. Power End of a Horizontal Power Pump.....	101
75. Reciprocating Pump Performance Curve .....	103
76. NPSHR for a Triplex Pump .....	107
77. Types of Misalignment.....	112
78. Checking Angular Misalignment .....	113
79. Dial Indicator Method of Checking	
Parallel Alignment .....	114
80. Straight Edge Method of Checking	
Parallel Alignment .....	115
81. Method of Checking Alignment on	
a Spacer Coupling .....	116
82. Correct Tension Check for V-belt Drives.....	117

**List of Tables**

1. Terminology for the Number of Plungers/Pistons	
on the Crankshaft.....	106
2. Effect of Number of Plungers on Variation from	
the Mean .....	106
3. Proper Spring Pull Tension for New and Used Belts.....	118

## INTRODUCTION

INDUSTRIALIZATION imposed an ever increasing demand for moving liquids from one location to another far more practically than by gravity. In order to motivate the liquid to move through the pipes and channels, energy has to be imparted to the liquid. The energy, usually mechanical, provided by a prime mover is transferred to the liquid by a device called a pump.

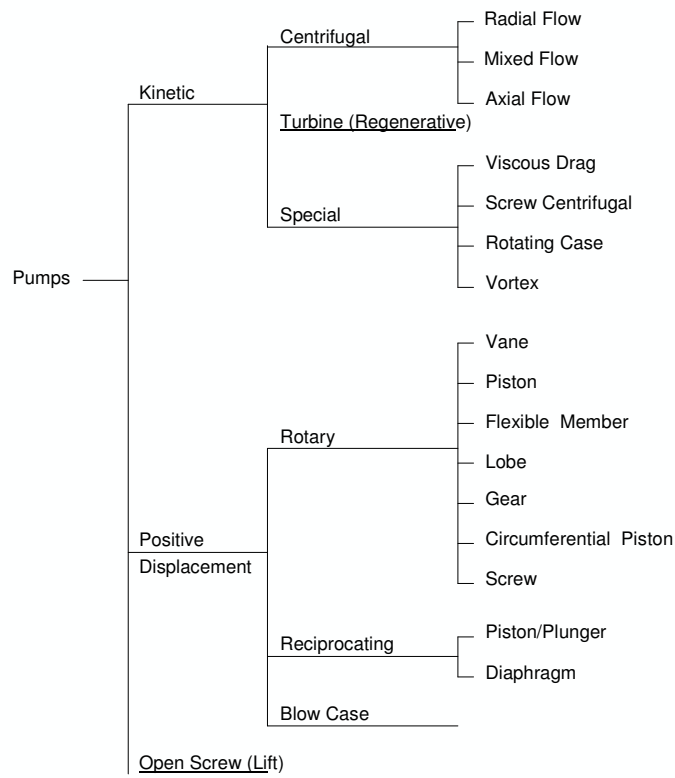
The English Gravitational System of Units is used throughout the guide as this system is familiar to technical personnel. It has also gained wide acceptance in the hydraulic machinery field both by the manufacturers and by their customers. Tables are provided in the Appendix for any necessary conversions.

# CLASSIFICATION OF PUMPS

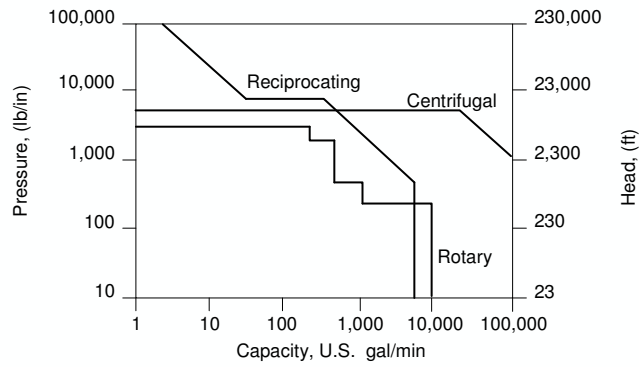
---

- There are numerous classes and categories of pumps due to the wide variation of processes and the distinct requirements of each application. Figure 1 illustrates the classes, categories, and types of pumps utilized in the world today.
- Figure 2 displays the approximate upper limits of pressure and capacity of the three major pump types.
- If the liquid can be handled by any of the three types within the common coverage area, the most economical order of selection would be the following:
  1. centrifugal
  2. rotary
  3. reciprocating
- However, the liquid may not be suitable for all three major pump types. Other considerations that may negate the selection of certain pumps and limit, choice include the following:
  - self priming
  - air -handling capabilities
  - abrasion resistance

- control requirements
- variation in flow
- viscosity
- density
- corrosion



**FIGURE 1. Classification of Pumps**



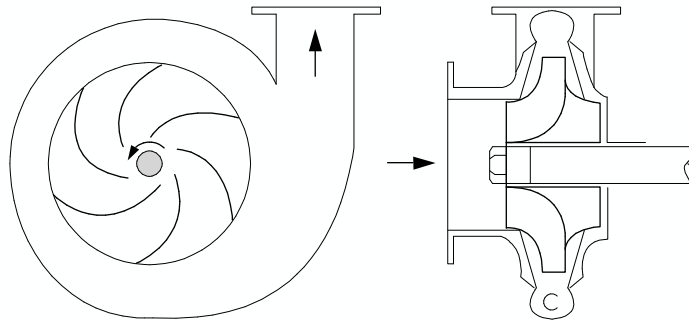
**FIGURE 2. Approximate Upper Performance Limits of Pump Types**

## KINETIC PUMPS

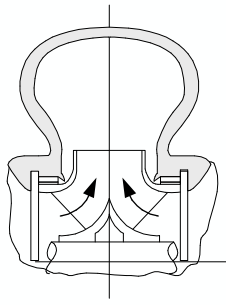
- Kinetic pumps are dynamic devices that impart the energy of motion (kinetic energy) to a liquid by use of a rotating impeller, propeller, or similar device.
- Kinetic pumps have the following characteristics:
  - discharge is relatively free of pulsation;
  - mechanical design lends itself to high throughputs, so that capacity limits are seldom a problem;
  - efficient performance over a range of heads and capacities;
  - discharge pressure is a function of fluid density and operational speed;
  - they are relatively small high speed devices;
  - they are economical.

## CENTRIFUGAL PUMPS

- All centrifugal pumps use but one pumping principle in that the impeller rotates the liquid at high velocity, thereby building up a velocity head (Figure 3).
- At the periphery of the pump impeller, the liquid is directed into a volute. The volute commonly has an increasing cross-sectional area along its length so that as the liquid travels along the chamber, its velocity is reduced.
- Since the energy level of the liquid cannot be dissipated at this point, the conservation of energy law (Bernoulli's theorem) requires that when the liquid loses velocity energy as it moves along the chamber, it must increase the energy related to pressure. Hence, the pressure of the liquid increases.
- The types of centrifugal pump are identified by the path of liquid flow as indicated below.



**FIGURE 3. Centrifugal Pump, Single Suction**



**FIGURE 4. Radial Flow, Double Suction**

Reproduced with permission of the Hydraulic Institute from *Hydraulic Institute Standards for Centrifugal, Rotary and Reciprocating Pumps*, 14th ed., 1983.

*Radial Flow*

- A pump in which the head is developed principally by the action of centrifugal force. The liquid enters the impeller at the hub and flows radially to the periphery (Figure 4).

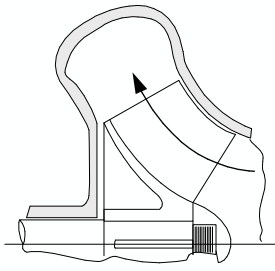
*Mixed Flow*

- A pump in which the head is developed partly by centrifugal force and partly by the lift of the vanes on the liquid. This type of pump has a single inlet impeller with the flow entering axially and discharging in an axial/radial direction (Figure 5).

*Axial Flow*

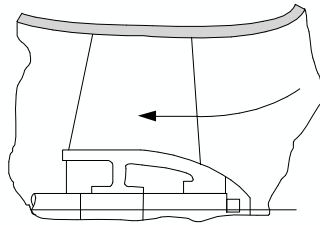
- This pump, sometimes called a propeller pump, develops most of its head by the propelling or lifting action of the vanes on the liquid. It has a single inlet impeller with the flow entering axially and discharging nearly axially (Figure 6).





**FIGURE 5. Mixed Flow**

Reproduced with permission of the Hydraulic Institute from *Hydraulic Institute Standards for Centrifugal, Rotary and Reciprocating Pumps*, 14th ed., 1983.

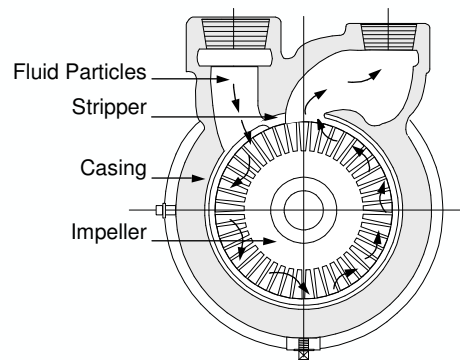


**FIGURE 6. Axial Flow**

Reproduced with permission of the Hydraulic Institute from *Hydraulic Institute Standards for Centrifugal, Rotary and Reciprocating Pumps*, 14th ed., 1983.

### TURBINE PUMPS (REGENERATIVE)

- Turbine pumps obtain their name from the many vanes machined into the periphery of the rotating impeller. Heads over 900 feet are readily developed in a two-stage pump.
- The impeller, which has very tight axial clearance and uses pump channel rings, displays minimal recirculation losses. The channel rings provide a circular channel around the blades of the impeller from the inlet to the outlet.
- Liquid entering the channel from the inlet is picked up immediately by the vanes on both sides of the impeller and pumped through the channel by the shearing action. The process is repeated over and over with each pass imparting more energy until the liquid is discharged (Figure 7).



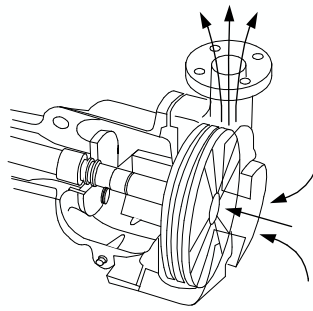
**FIGURE 7. Turbine Pump**

Reproduced with permission of the Hydraulic Institute from *Hydraulic Institute Standards for Centrifugal, Rotary and Reciprocating Pumps*, 14th ed., 1983.

## SPECIAL PUMPS

### *Viscous Drag or Disk Pump*

- The viscous drag pump operation utilizes two principles of fluid mechanics: boundary layer and viscous drag. These phenomena occur simultaneously whenever a surface is moved through a liquid.
- Boundary layer phenomenon occurs in the disk pump when liquid molecules lock onto the surface roughness of the disk rotor. A dynamic force field is developed. This force field produces a strong radially accelerating friction force gradient within and between the molecules of the fluid and the disks, thereby creating a boundary layer effect.



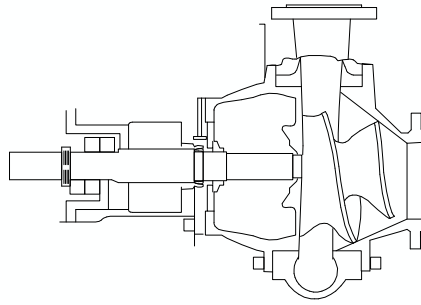
**FIGURE 8. Viscous Drag Pump**

Reproduced with permission of the Fairmont Press Inc. from Garay, P. N.  
*Pump Application Desk Book*, 1990.

- The resulting frictional resistance force field between the interacting elements and the natural inclination of a fluid to resist separation of its own continuum, creates the adhesion phenomenon known as viscous drag. These effects acting together are the motivators in transferring the necessary tangential and centrifugal forces to propel the liquid with increasing momentum towards the discharge outlet located at the periphery of the disks (Figure 8).
- Advantages of using a viscous drag pump
  - minimal wear with abrasive materials
  - gentle handling of delicate liquids
  - ability to easily handle highly viscous liquids
  - freedom from vapor lock.

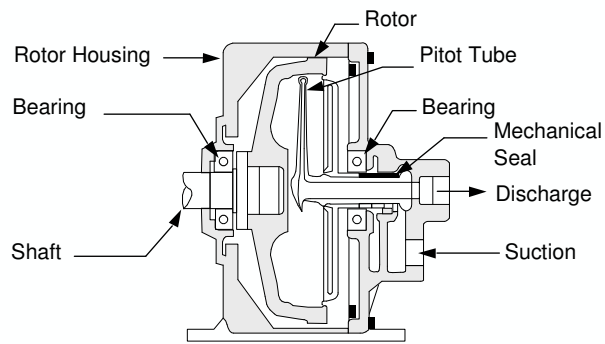
#### *Screw Centrifugal Pump*

- This pump incorporates a large-diameter screw instead of the more common radial impeller that is found in centrifugal pumps (Figure 9).
- Thick sludge and large particle solids can be moved because of the low Net Positive Suction Head (NPSH) requirements, which result from the utilization of the inducer-like impeller.
- Because the pumped material enters at a low entrance angle, a low shear, low turbulence condition exists, which results in very gentle handling of the liquid. The gentle handling makes it possible to pump slurries of fruits and vegetables without undue breakup of constituents.



**FIGURE 9. Screw Centrifugal Pump**

Reproduced with permission of the Fairmont Press Inc. from Garay, P. N.  
*Pump Application Desk Book*, 1990.



**FIGURE 10. Rotating Case Pump**

Reproduced with permission of McGraw-Hill from Karassik, I. J. (ed).  
*Pump Handbook*, 2nd ed., 1986.

- The pump can also be operated in the reverse direction. This characteristic is advantageous for clearing clogged suction lines.

#### *Rotating Case Pump*

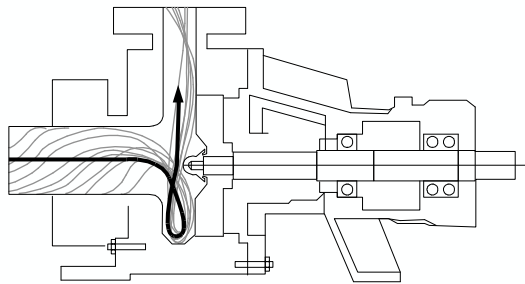
- The basic concept of this pump is unique (Figure 10). Liquid enters the intake manifold and passes into a rotating case where centrifugal force accelerates it. A stationary pickup tube situated on the inner edge of the case, where pressure and velocity are the greatest, converts the centrifugal energy into a steady pulsation-free high pressure stream.
- The following characteristics attest to the simplicity of the pump:
  - only one rotating part (the casing)
  - the seal is exposed only to suction pressure
  - no seal is required at the high pressure discharge
- The pump, turning at speeds from 1,325 to 4,500 rpm will generate heads approximately four times that of a single-stage centrifugal pump operating at a similar speed. Single-stage heads up to 3,000 feet are readily attainable even in sizes up to 200 gpm.

#### *Vortex Pump*

- A vortex pump comprises a standard concentric casing with an axial suction intake and a tangential discharge nozzle (Figure 11). The straight radial-bladed impeller is axially recessed in the casing. The recess can range from 50% to 100% where the impeller is completely out of the flow stream. The rotating impeller creates a vortex field in the casing that motivates the liquid from the centrally located suction to the tangentially

located discharge. Because the pumped liquid does not have to flow through any vane passages, solid content size is limited only by the suction and discharge diameters.

- A vortex pump can handle much larger percentages of air and entrained gases than a standard centrifugal pump because pumping action is by induced vortex rather than by impeller vanes.
- Advantage of a vortex pump
  - can handle high solid-content liquids, entrained gas liquids, and stringy sewage while requiring a relatively low NPSH.
- Disadvantage of a vortex pump
  - comparatively low efficiency of 35% to 55%.



**FIGURE 11. Vortex Pump**

Reproduced with permission of McGraw-Hill from Karassik, I. J. (ed).  
*Pump Handbook*, 2nd ed., 1986.

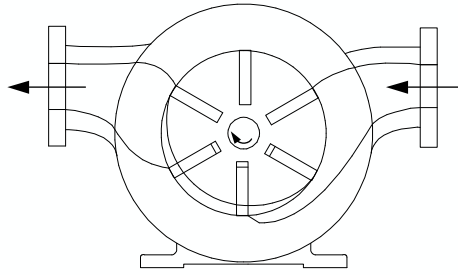
## POSITIVE DISPLACEMENT PUMPS

- In these pumps, the liquid is forced to move because it is displaced by the movement of a piston, vane, screw, or roller. The pumps force liquid into the system regardless of the resistance that may oppose the transfer.
- Some common characteristics of these pumps are
  - adaptable to high pressure operation;
  - variable flow rate through the pump is possible; (auxiliary damping systems may be used to reduce the magnitude of pressure pulsation and flow variation);
  - maximum throughputs are limited by mechanical considerations;
  - capable of efficient performance at extremely low volume throughput rates.
- Advantage of positive displacement pumps
  - higher overall efficiency than centrifugal pumps because internal losses are minimized.

### ROTARY PUMPS

- This pump is a positive displacement pump that consists of the following:
  - a chamber that contains gears, cams, screws, lobes, plungers, or similar devices actuated by rotation of the drive shaft;
  - no separate inlet and outlet valves;
  - tight running clearances.





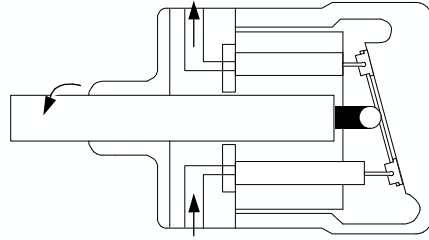
**FIGURE 12. Sliding Vane Pump**

*Vane Pump*

- This pump utilizes vanes in the form of blades, buckets, rollers, or slippers, which act in conjunction with a cam to draw liquid into and force it from the pump chamber.
- A vane pump may be constructed with vanes in either the rotor or stator and with radial hydraulic forces on the rotor balanced or unbalanced. The vane in rotor pumps may be made with constant or variable displacement pumping elements.
- Figure 12 illustrates a vane in rotor constant displacement unbalanced pump.

*Piston Pump*

- In this pump, liquid is drawn in and forced out by pistons that reciprocate within cylinders. The valving is j20



accomplished by rotation of the pistons and cylinders relative to the ports.

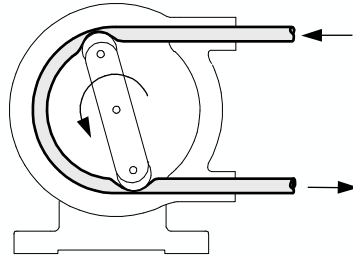
**FIGURE 13. Axial Piston Pump**

The cylinders may be axially or radially positioned and arranged for either constant or variable displacement pumping.

- All types of piston pumps are constructed with multiple pistons except that the constant displacement radial type may be either single or multiple piston.
- Figure 13 shows an axial constant displacement piston pump.

*Flexible Member Pump*

- In this pump, the liquid pumping and sealing action depends on the elasticity of the flexible members. The flexible member may be a tube, a vane, or a liner.



- Figure 14 illustrates a flexible tube pump.

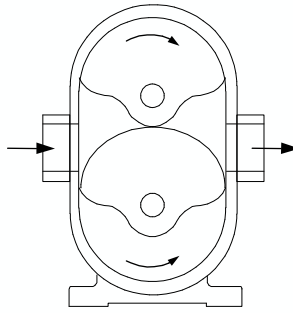
**FIGURE 14. Flexible Tube Pump**

*Lobe Pump*

- In this pump, liquid is carried between rotor lobe surfaces from the inlet to the outlet. The rotor surfaces mate and provide continuous sealing. The rotors must be timed by separate means. Each rotor has one or more lobes. Figure 15 illustrates a single lobe pump.

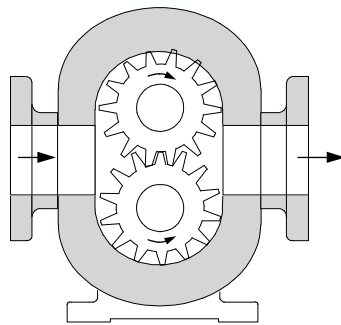
*Gear Pump*

- In this pump, fluid is carried between gear teeth and displaced when the teeth engage. The mating surfaces of the gears mesh and provide continuous sealing. Either rotor is capable of driving the other.
- External gear pumps have all gear cut externally. These may have spur, helical, or herringbone gear teeth and may use



timing gears. Figure 16 illustrates an external spur gear pump.

**FIGURE 15. Single Lobe Pump**

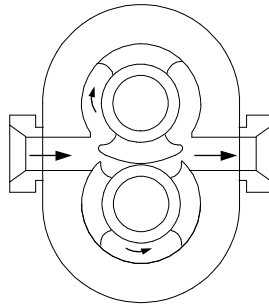


**FIGURE 16. External Gear Pump**

- Internal gear pumps have one rotor with internally cut gear teeth that mesh with an externally cut gear. These pumps are made with or without a crescent-shaped partition.

*Circumferential Piston Pump*

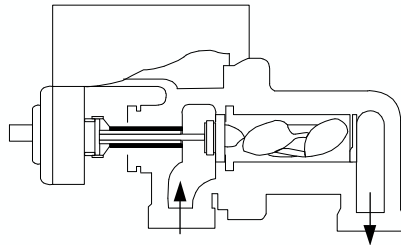
- In this pump (Figure 17), liquid is carried from inlet to outlet in spaces between piston surfaces. There are no sealing contacts between rotor surfaces.
- In the external circumferential piston pump, the rotors must be timed by separate means and each rotor may have one or more piston elements.
- In the internal circumferential piston pump, timing is not required, and each rotor must have two or more piston elements.



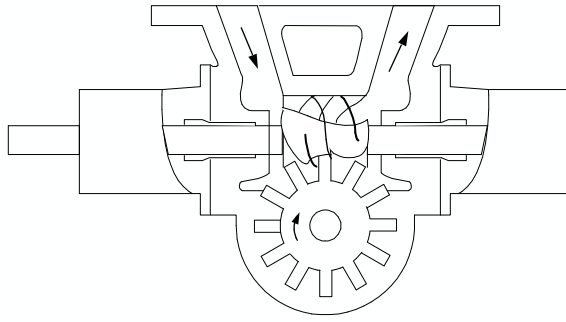
**FIGURE 17. Circumferential, External Piston Pump**

### *Screw Pump*

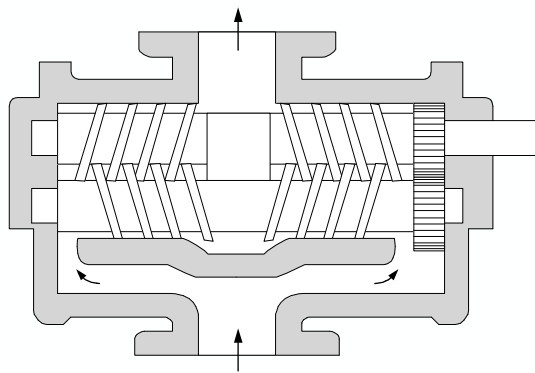
- In this pump, liquid is carried in spaces between screw threads and is displaced axially as these threads mesh.
- This pump has a rotor with external threads and a stator with internal threads. The rotor threads are eccentric to the axis of rotation. Figure 18 illustrates a single-screw pump commonly called a progressive cavity pump.
- The screw and wheel pump (Figure 19) depends upon a plate wheel to seal the screw so that there is no continuous cavity between the inlet and outlet.
- Multiple screw pumps have multiple external screw threads. Such pumps may be timed or untimed. Figure 20 illustrates a timed screw pump.



**FIGURE 18. Single-Screw Pump  
(Progressive Cavity)**



**FIGURE 19. Screw and Wheel Pump**



**FIGURE 20. Two-Screw Pump**

## RECIPROCATING PUMPS

- Reciprocating pumps utilize the principle of a moving piston, plunger, or diaphragm to draw liquid into a cavity through an inlet valve and push it out through a discharge valve.
- These pumps have overall efficiency ranges from 50% for the small capacity pumps to 90% for the larger capacity sizes.
- They can handle a wide range of liquids, including those with extremely high viscosities, high temperatures, and high slurry concentrations due to the pump's basic operating principle, i.e., the pump adds energy to the liquid by direct application of force, rather than by acceleration.
- **Note:** For a highly viscous liquid, ensure that the fluid flows into the pumping chamber so it can be displaced. At times it may be necessary to slow the pump to give the viscous liquid time to fill the chamber on each stroke. The head on the viscous liquid must be sufficient to move the liquid into the pump cylinder.

### *Piston/Plunger Pump*

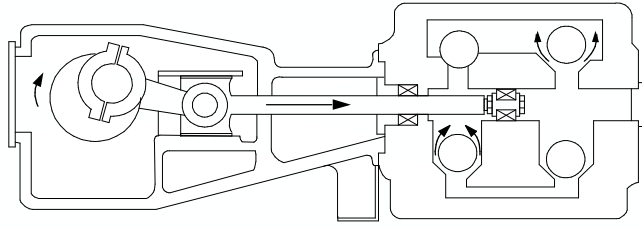
- A tight-fitting piston in a closed cylinder or a loose-fitting plunger acting as a displacer are familiar versions of the common reciprocating pump.
- Piston/plunger pumps have the following characteristics:
  - capable of almost any pressure, and of large flow capacity;
  - not as popular as they were before efficient centrifugal types dominated the market;
  - NPSH requirements for these pumps are more complex than for rotary or kinetic pumps due to the pulsed nature of the suction;
  - are expensive in large sizes.



- Advantages include the following:
  - easily controlled by stroke adjustment or variable speed
  - the ability to develop high pressures in a single stage
  - high reliability
- Disadvantages include the following:
  - the necessity of slow speed operation
  - a pulsed output.
- Figure 21 illustrates a typical double-acting piston power pump.

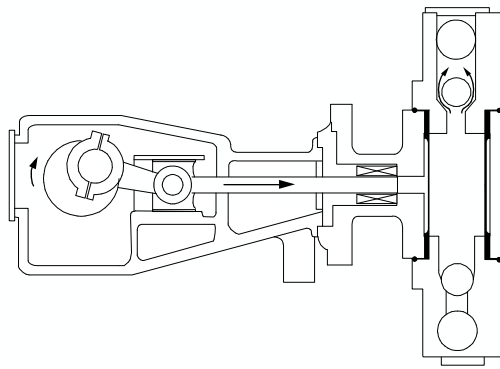
#### *Diaphragm Pump*

- Fluid is transferred by the pressure of a diaphragm that flexes to form a cavity that is filled by liquid.
- A diaphragm pump has the following characteristics:
  - transfers virtually any liquid;
  - designs can handle high temperatures;
  - is infinitely adjustable in capacity and discharge pressure by regulating the movement of the diaphragm;
  - can be flexed by either an air supply or a reciprocating plunger;
  - is used for pumping chemicals, glue, ink, solvents, fat, grease, and dirty water;
  - is limited to low flow and head application due to the design of the flexible diaphragm.
- Figure 22 displays a typical diaphragm pump motivated by a reciprocating plunger.



**FIGURE 21. Horizontal Double-Acting  
Piston Power Pump**

Reproduced with permission of the Hydraulic Institute from *Hydraulic Institute Standards for Centrifugal, Rotary and Reciprocating Pumps*, 14th ed., 1983.



**FIGURE 22. Diaphragm Pump**

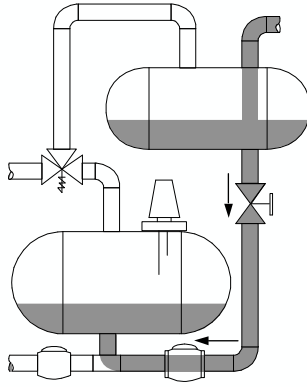
Reproduced with permission of the Hydraulic Institute from *Hydraulic Institute Standards for Centrifugal, Rotary and Reciprocating Pumps*, 14th ed., 1983.

## BLOW CASE PUMP

- This is a special configuration of a positive displacement pump (Figure 23). It consists of two pressure chambers that are alternately filled with liquid. When a chamber is filled, air or steam is forced into the chamber. This causes the contents to be discharged into the system. The two chambers alternate in this action, resulting in a fairly constant discharge.
- It is popular for pumping hot condensate: because there is no heat loss, and flashing liquid can be transferred.

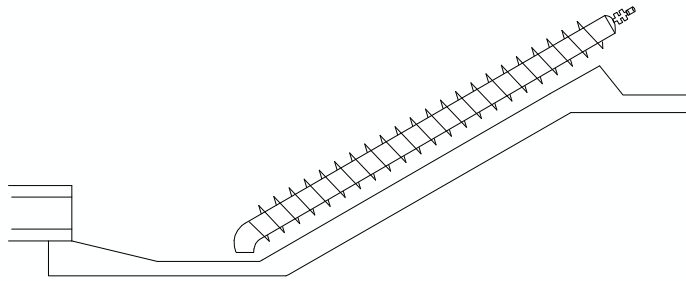
## OPEN-SCREW PUMP

- This is an example of a pump configuration that does not conform to the classical forms discussed in the preceding sections.
- An open-screw pump consists of a U-shaped channel into which a rotating screw fits tightly (minimal clearance). The channel, angled at inclinations of up to  $45^{\circ}$ , takes liquid from a lower level and literally “screws” the water from the lower to the higher level.
- The open-screw pump does not develop any pressure as it is merely a conveyor. Modern forms of this pump are usually quite large.
- This pump is used extensively in waste water plants for moving contaminated water, and in irrigation channels for lifting large volumes of water. An open-screw pump is well suited for this purpose as there is little chance of down time. The large sizes with closely fitted screws are reasonably efficient. One version surrounds the screw within a large tube and the whole assembly is then rotated. All bearings are thus outside of the liquid and there is no liquid leakage. Figure 24 illustrates the conventional screw pump.



**FIGURE 23. Blow Case Pump**

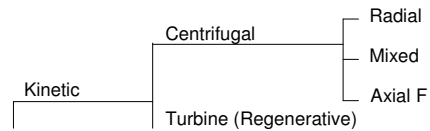
Reproduced with permission of the Fairmont Press Inc. from Garay, P. N.  
*Pump Application Desk Book*, 1990.



**FIGURE 24. Conventional Screw Pump**

# CENTRIFUGAL PUMPS:

*Principles, Components, Performance*



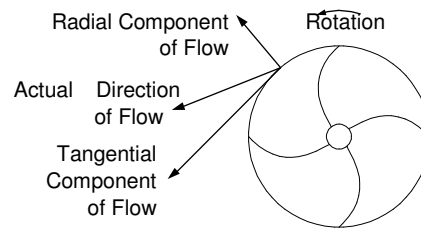
- Universally, the centrifugal pump is the most popular type of pump due to its durability, versatility, simplicity, and economics. This chapter explains the distinctive features and unique operating characteristics of this pump.

## OPERATING PRINCIPLES

- A centrifugal pump has the following characteristics:
  - it is made up of a set of rotating vanes that are enclosed within a housing. These vanes are utilized to impart energy to a liquid through centrifugal force.
  - it consists of two main parts: a rotating element including an impeller and a shaft; and a stationary element made up of a casing, stuffing box, and bearings.

- it transfers the energy provided by a prime mover, such as an electric motor, steam turbine, or gasoline engine to energy within the liquid being pumped. This energy within the liquid is present as a velocity energy, pressure energy, or a combination of both.

- The method by which this energy conversion is accomplished is unique. The rotating element of a centrifugal pump, which is motivated by the prime mover, is the impeller. The liquid being pumped surrounds the impeller, and as the impeller rotates, the rotating motion of the impeller imparts a rotating motion to the liquid. There are two components to the motion imparted to the liquid by the impeller: one motion is in the radial direction outward from the center of the impeller. This motion is caused by the centrifugal force, due to the rotation of the liquid, which acts in a direction outward from the centre of the rotating impeller. Also, as the liquid leaves the impeller, it tends to move in a direction tangential to the outside diameter of the impeller.
- The actual liquid direction is a result of the two flow directions (Figure 25).



**FIGURE 25. Liquid Flow Direction**

- The amount of energy being added to the liquid by the rotating impeller is related to the velocity with which the liquid moves. The energy expressed as pressure energy will be proportional to the square of the resultant exit velocity:

$$H = \frac{V^2}{2g}$$

H = energy (ft of liquid)

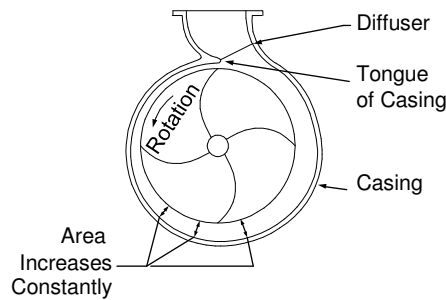
V = velocity (ft/sec)

g = acceleration due to gravity (ft/sec)

- From these facts, two things can be predicted
  - any increase in the impeller tip velocity will increase the energy imparted to the liquid.
  - any change in the vane tip velocity will result in a change in the energy imparted to the liquid that is proportional to the square of the change in tip velocity.
- **For example:** Doubling the rotative speed of the impeller would double the tip speed, which in turn would quadruple the energy imparted to the liquid.
  - doubling the impeller diameter would double the tip speed, which again would quadruple the energy imparted to the liquid.
- Points to note about the liquid that is being discharged from the tip of the impeller are that
  - the liquid is being discharged from all points around the impeller periphery.
  - the liquid is moving in a direction that is generally outward from and around the impeller.

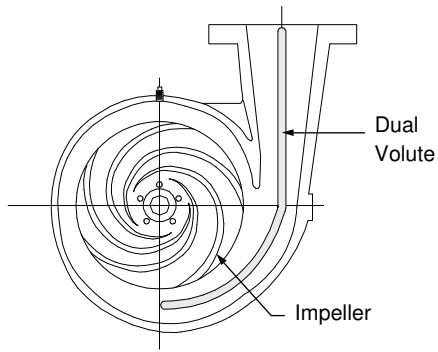
- the function of the casing is to gather and direct the liquid to the discharge nozzle of the pump. The casing is designed so that, at one point, the wall of the casing is very close to the impeller periphery. This point is called the tongue or shear water of the casing. Figure 26 illustrates a typical casing design.

- At a point just before the tongue, all the liquid discharged by the impeller has been collected and is ready to be lead into the discharge pipe. In most cases, this liquid possesses a higher velocity than would be feasible to handle because high velocity means a high frictional loss in the discharge piping. The velocity in the discharge nozzle is decreased by increasing the area for flow (volute chamber).
- **Note:** As the area increases, the velocity decreases. This velocity can be converted into pressure energy by either of the following: a volute (Figure 27), or a set of diffusion vanes surrounding the impeller periphery (Figure 28).



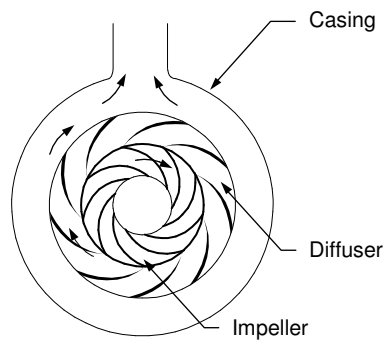
**FIGURE 26. Typical Centrifugal Pump Casing**





**FIGURE 27. Volute Casing**

Reproduced with permission of McGraw-Hill from Karassik, I. J. (ed).  
*Pump Handbook*, 2nd ed., 1986.



**FIGURE 28. Diffusion Vane Casing**

Reproduced with permission of McGraw-Hill from Karassik, I. J. (ed).  
*Pump Handbook*, 2nd ed., 1986.

## CENTRIFUGAL PUMP CLASSIFICATIONS AND SUB-DIVISIONS

- A single-stage pump
  - one in which the head is developed by a single impeller.
- A multi-stage pump
  - one in which the total head to be developed requires the use of two or more impellers operating in series, each taking its suction from the discharge of the preceding impeller.
- The mechanical design of the casing provides the following pump classifications:
  - axially split
  - radially split
- The axis of rotation determines whether it is a horizontal or vertical unit.
- Horizontalshaft centrifugal pumps are still further classified according to the suction and/or discharge nozzle
  - end suction
  - side suction
  - bottom suction
  - top suction
- Vertical shaft pumps
  - vertical pump types are submerged in their suction supply.

- vertical shaft pumps are therefore called either dry-pit or wet-pit types. If the wet-pit pumps are axial flow, mixed flow, or vertical turbine types, the liquid is discharged up through the supporting column to a discharge point above or below the supporting floor. These pumps are thus designated as above-ground discharge or below-ground discharge units.

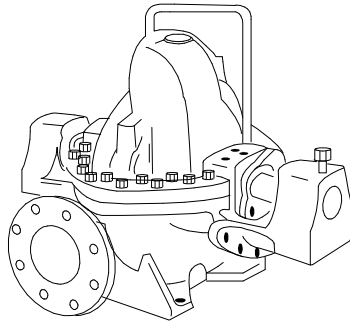
## CENTRIFUGAL PUMP COMPONENTS

- Centrifugal pumps comprise of the following parts:
  - casing
  - impeller
  - wearing rings (impeller, casing)
  - shaft and shaft sleeves
  - stuffing box
  - mechanical seals
  - bearings
  - bearing frame
- The section below will briefly explain the features of each component.

### CASING

#### *Solid Casing*

- Solid casing implies a design in which the discharge waterway leading to the discharge nozzle is contained in one cavity. Because the sidewalls surrounding the impeller are part of the casing, a solid casing designation cannot be used, and designs normally called *solid casings* are, in fact, *radially split casings*.



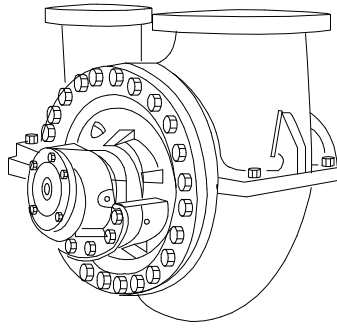
**FIGURE 29. Axially Split Casing**

*Split Casing*

- A split casing comprises of two or more parts (top and bottom) fastened together. The term *horizontally split* had been regularly used to describe pumps with a casing divided by a horizontal plane through the shaft center line or axis (Figure 29). The term *axially split* is now preferred.
- The term *vertically split* refers to a casing split in a plane perpendicular to the axis of rotation (Figure 30). The term *radially split* is now preferred.

**IMPELLERS**

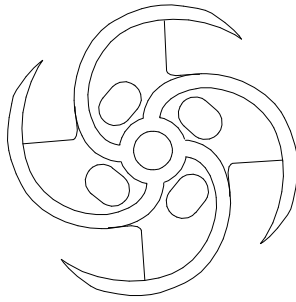
- Impellers are normally classified into the following mechanical types:
  - open
  - semi-open
  - enclosed



**FIGURE 30. Radially Split Casing**

*Open Impeller*

- An open impeller consists of vanes attached to a central hub without any form of sidewall or shroud (Figure 31).
- Disadvantage of an open impeller
  - *Structural weakness* - if the vanes are long, they must be strengthened by ribs or a partial shroud. Generally, open impellers are used in small inexpensive pumps or pumps that handle abrasive liquids.
- Advantage of an open impeller
  - it is capable of handling suspended matter with a minimum of clogging.
- The open impeller rotates between two side plates, between the casing walls of the volute. The clearance between the impeller vanes and sidewalls allows a certain amount of water recirculation, which increases as wear



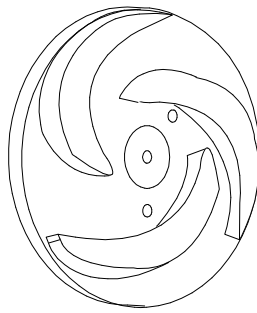
**FIGURE 31. Open Impeller**

Reproduced with permission of McGraw-Hill from Karassik, I. J. (ed).  
*Pump Handbook*, 2nd ed., 1986.

increases. To restore the original efficiency, both the impeller and the side plates must be replaced. This is a much greater expense than would be encountered by an enclosed impeller where simple rings form the leakage point.

#### *Semi-Open Impeller*

- The semi-open impeller incorporates a shroud or an impeller backwall (Figure 32). This shroud may or may not have “pump-out” vanes, which are located at the back of the impeller shroud.
- Function of the “pump-out” vanes
  - to reduce the pressure at the back hub of the impeller;
  - to prevent foreign matter from lodging in the back of the impeller and interfering with the proper operation of the pump and the stuffing box.

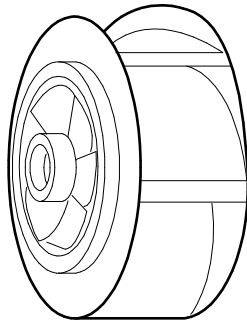


**FIGURE 32. Semi-Open Impeller**

Reproduced with permission of McGraw-Hill from Karassik, I. J. (ed).  
*Pump Handbook*, 2nd ed., 1986.

*Enclosed Impeller*

- The enclosed impeller is used universally in centrifugal pumps that handle clear liquids (Figure 33). It incorporates shrouds or enclosing sidewalls that totally enclose the impeller “waterways” from the suction eye to the impeller periphery.
- This design prevents the liquid recirculation that occurs between an open or semi-open impeller and its side plates. A running joint must also be provided between the impeller and the casing to separate the discharge and suction chambers of the pump. The running joint is normally formed by a relatively short cylindrical surface on the impeller shroud that rotates within a slightly larger stationary cylindrical surface. If one or both surfaces are made removable, the “leakage joint” can be repaired when wear causes excessive leakage.



**FIGURE 33. Enclosed Impeller**

Reproduced with permission of McGraw-Hill from Karassik, I. J. (ed).  
*Pump Handbook*, 2nd ed., 1986.

#### *Impeller Suction*

- Impellers are further identified by the suction parameters.
- In a single-suction impeller, the liquid enters the suction eye on one side of the impeller only.
- In a double-suction impeller, which is two single-suction impellers arranged back to back in a single casing, the pumped liquid enters the impeller eye simultaneously from both sides while the two casing suction passageways are connected to a common suction passage.
- For the general service single-stage axially split casing design, a double-suction impeller is favored because:
  - it is theoretically in axial hydraulic balance;
  - the greater suction area of a double-suction impeller permits the pump to operate with less net absolute suction head.
- End suction pumps with single-suction overhung impellers have both initial costs and maintenance advantages not



obtainable with a double-suction impeller. Most radially split casing pumps therefore use single-suction impellers. Because an overhung impeller does not require the extension of a shaft into the impeller eye, single-suction impellers are preferred for pumps that handle suspended matters such as sewage.

- Multi-stage pumps can use single or double suction impellers to achieve the hydraulic performance. As the number of impellers increases, the pump total head, the complexity, and the cost of the unit increases.

#### *Impeller Vane Shape and Form*

- Impellers can also be classified by the shape and form of their vanes as follows:
  - the straight-vane impeller (radial)
  - the mixed-flow impeller
  - the axial-flow impeller or propeller
  - Francis vane
  - backward curved vane

#### *Straight-Vane Impeller*

- In a straight-vane impeller, the vane surfaces are generated by a straight line parallel to the axis of rotation. These vanes are also called *single curvature vanes*.

#### *Mixed-Flow Impeller*

- An impeller design that has both radial and axial flow components is a mixed-flow impeller. It is generally restricted to single-suction designs with a specific speed above 4,200. Types with lower specific speeds are called *Francis vane impellers*.

### *Axial-Flow Impeller*

- Mixed-flow impellers with a very small radial flow component are usually referred to as propellers. In a true propeller or axial-flow impeller, the flow strictly parallels the axis of rotation.

### *Specific Speed*

- Calculating specific speed is one method of classifying the pump impellers with reference to their geometric similarity.
- Specific speed is a correlation of pump capacity, head, and rotative speed and can be described by the following formula:

$$N_s = \frac{N\sqrt{Q}}{H^{3/4}}$$

where:

N<sub>s</sub> = specific speed

N = rotative speed, (rpm)

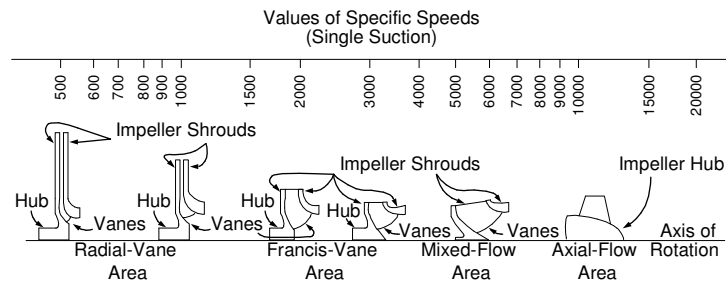
Q = flow at optimum efficiency, (gpm US)

H = total head (ft/stage)

- Figure 34 shows the relationship of specific speed to single-suction impeller profiles.

### *Vane Shape*

- Classification of impellers according to their vane shape is arbitrary as there is a great deal of overlapping in the types of impellers used in different types of pumps. **For example:** Impellers in single- and double-suction pumps of low specific speed have vanes extending across the suction eye. This provides a mixed flow at the impeller entrance for low pick-up losses at high rotative speeds, but allows the discharge portion of the impeller to use the straight-vane principle.



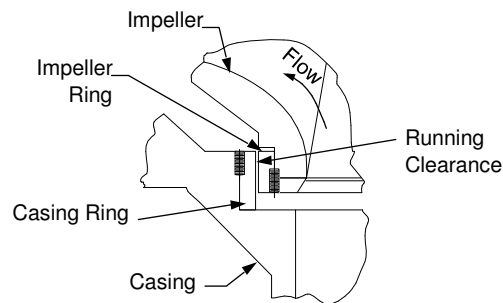
**Figure 34. Impeller Profile vs. Specific Speed**

Reproduced with permission of the Hydraulic Institute from *Hydraulic Institute Standards for Centrifugal, Rotary and Reciprocating Pumps*, 14th ed., 1983.

- In pumps of higher specific speed operating against low heads, impellers have double-curvature vanes extending over the full vane surface.
- Many impellers are designed for specific applications.  
**For example:** The conventional impeller design with sharp vane edges and restricted areas is not suitable for handling liquids that contain rags, stringy material, and solids such as sewage because it will become clogged. Special non-clogging impellers with blunt edges and large waterways have been designed for such service.
- The impeller design used for paper pulp or sewage pumps is fully open, non-clogging and has screw and radial streamlined vanes. The vane's leading edge projects far into the suction nozzle permitting the pump to handle pulp stocks with a high consistency of paper.

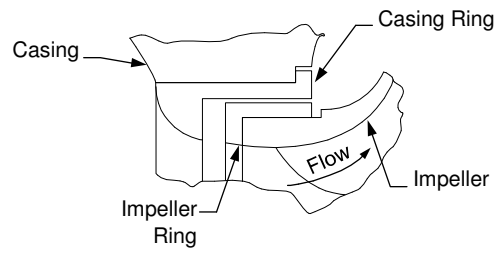
## WEARING RINGS

- Wearing rings (for casing or impeller) provide an easily and economically renewable leakage joint.
- There are various types of wearing ring designs, and the selection of the most desirable type depends on the following:
  - liquid being handled
  - pressure differential across the leakage joint
  - rubbing speed
  - pump design (i.e., sewage vs. clean liquid)
- The most common ring constructions are the flat type (Figure 35) and the “L” type (Figure 36).
- Some designers favor labyrinth-type rings, which have two or more annular leakage joints connected by relief chambers (Figure 37).



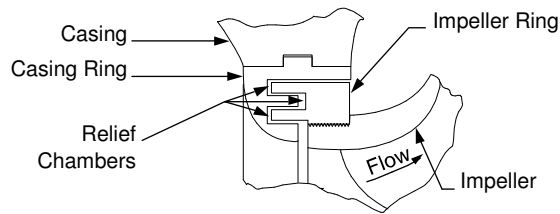
**FIGURE 35. Flat-Type Wearing Ring**

Reproduced with permission of McGraw-Hill from Karassik, I. J. (ed).  
*Pump Handbook*, 2nd ed., 1986.



**FIGURE 36. "L"-Type Wearing Ring**

Reproduced with permission of McGraw-Hill from Karassik, I. J. (ed).  
*Pump Handbook*, 2nd ed., 1986.



**FIGURE 37. Double-Labyrinth-Type Wearing Ring**

Reproduced with permission of McGraw-Hill from Karassik, I. J. (ed).  
*Pump Handbook*, 2nd ed., 1986.

- In leakage joints involving a flat-type wearing ring, the leakage flow is a function of the following:
  - area
  - length of the joint
  - pressure differential across the joint
- If the path is broken by relief chambers, the velocity energy in the leakage jet is dissipated in each relief chamber, thereby increasing the resistance. As a result, with several relief chambers and several leakage joints for the same actual flow through the joint, is less resulting in higher pump performance and operating efficiency.

#### SHAFTS AND SHAFT SLEEVES

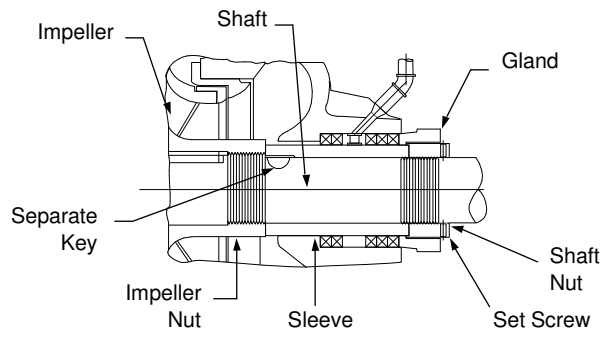
##### *Shafts*

- The basic function of a centrifugal pump shaft is to:
  - transmit the torques encountered in starting and during operation while supporting the impeller and other rotating parts;
  - perform with a deflection that is less than the minimum clearance between rotating and stationary parts (i.e., wearing rings, mechanical seals).
- The loads involved are as follows:
  - torques
  - weight of the parts
  - axial and radial hydraulic forces
- Shafts are usually designed to withstand the stress set up when a pump is started quickly.

- Critical speed is another concern. Any object made of an elastic material has a natural period of vibration. When a pump impeller and shaft rotate at any speed corresponding to the natural frequency, minor imbalances will be magnified.
- The speeds at which this magnification takes place are called *critical speeds*
  - the lowest critical speed is called the *first critical speed*
  - the next higher is called the *second critical speed*, etc.
- In centrifugal pump nomenclature:
  - a rigid shaft means one with an operating speed lower than its first critical speed;
  - a flexible shaft is one with an operating speed higher than its first critical speed. The shaft critical speed can be reached and passed without danger because frictional forces (surrounding liquid, stuffing box packing, various internal leakage joints) tend to restrain the deflection for a short duration.

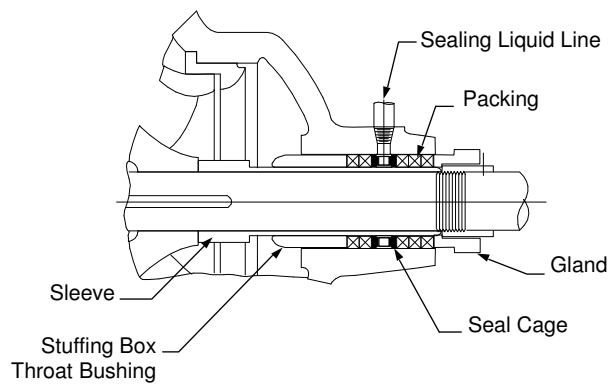
#### *Shaft Sleeves*

- Pump shafts are usually protected from erosion, corrosion, and wear at stuffing boxes, leakage joints, internal bearings, and in the waterways by renewable sleeves.
- The most common shaft sleeve function is that of protecting the shaft from packing wear at the stuffing box. Figure 38 shows a typical stuffing box sleeve application.



**FIGURE 38. Stuffing Box Sleeve**

Reproduced with permission of McGraw-Hill from Karassik, I. J. (ed).  
*Pump Handbook*, 2nd ed., 1986.



**FIGURE 39. Conventional Stuffing Box**

Reproduced with permission of McGraw-Hill from Karassik, I. J. (ed).  
*Pump Handbook*, 2nd ed., 1986.



### STUFFING BOX

- The primary function of a stuffing box is to prevent leakage at the point where the shaft passes out through the pump casing. For general service pumps, a stuffing box consists of a cylindrical recess that accommodates a number of rings of packing seal cage and gland around the shaft or shaft sleeve.
- Figure 39 shows a conventional stuffing box.
- If sealing liquid to the box is desired, a lantern ring or seal cage is used, which separates the rings of packing into approximately equal sections. The packing is compressed to give the desired fit on the shaft or sleeve by a gland that can be adjusted in an axial direction. A small leakage from the stuffing box is required to provide lubrication and cooling.

### MECHANICAL SEALS

- Designers have produced mechanical seals to overcome packing disadvantages and to provide a positive seal for liquids that are toxic.
- Disadvantages of using conventional packing
  - it is impractical to use as a method for sealing a rotating shaft for many conditions of service. Attempts to reduce or eliminate all leakage from a conventional stuffing box have the effect of increasing the gland pressure. The packing, which is semiplastic in nature, forms more closely to the shaft and tends to reduce the leakage. At a certain point of tightening the gland nut, the leakage continues regardless of how tightly the gland is turned. The frictional horsepower increases rapidly, which generates heat that cannot be dissipated. The stuffing box fails to

function as illustrated by severe leakage and a heavily scored shaft or sleeve.

- Disadvantages of using stuffing boxes for certain applications
  - the minimal lubricating value of many liquids, e.g., butane and propane handled by centrifugal pumps. These liquids act as a solvent for the lubricants that are usually used to impregnate the packing. Seal oil must be introduced to lubricate the packing and give it reasonable life.
- All mechanical seals are fundamentally the same in principle. Sealing surfaces of every kind are located in a plane perpendicular to the shaft and usually consist of two highly polished surfaces running adjacently: one surface connected to the shaft and the other to the stationary portion of the pump. Complete sealing is accomplished at the fixed member. The lapped surfaces that are of dissimilar materials are held in continual contact by a spring, forming a fluid tight seal between the rotating and stationary components with very little frictional losses.

#### *Mechanical Seal Advantages*

- Advantages of the mechanical seal over the packing seal are
  - *Controlled leakage* - a mechanical seal requires some lubrication of the sealing faces to operate properly. The amount of leakage across the faces is minimal.
  - *High suction pressure* - mechanical seals can be designed to operate successfully at higher pressures than packing can withstand.
  - *Resistance to corrosives* - mechanical seals are available in practically any corrosion-resistant material and, unlike packing, are not limited to a few basic materials.

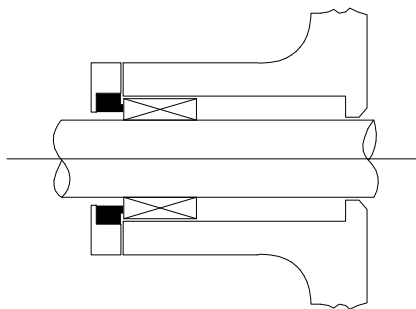
- *Prevents product contamination.*
- *Special features* - mechanical seals can be supplied with many integral modifications, such as flushing, cooling, and quenching, which are all designed to prolong seal life.
- *Reduced maintenance* - if a mechanical seal is installed correctly, it should require no further service.

#### *Mechanical Seal Types*

- Mechanical seals are classified by their location (mounted internally or externally), arrangement, and design.

#### Single Internal Seal

- The rotating assembly of the seal is located in the liquid that is being pumped (Figure 40).

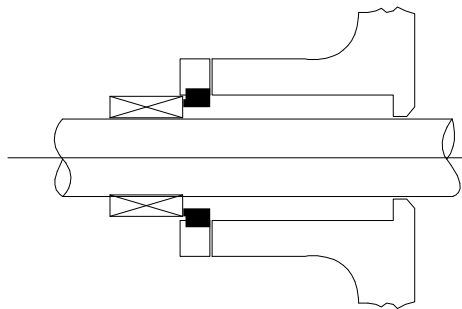


**FIGURE 40. Single Internal Seal**

- The following is a list of advantages of a single internal seal:
  - can be used on high pressure as the seal faces are forced together
  - seal parts are not exposed to abrasive or corrosive atmospheric conditions
  - cannot be easily tampered with by inexperienced personnel because the parts are within the pump
  - more easily modified to handle extremes in operating conditions
  - can be used where available space is limited

#### Single External Seal

- The rotating seal assembly is located outside the liquid. The seal is normally mounted outside the stuffing box (Figure 41).

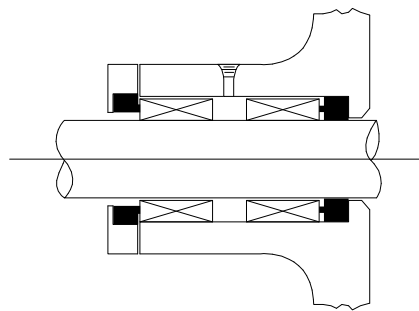


**FIGURE 41. Single External Seal**

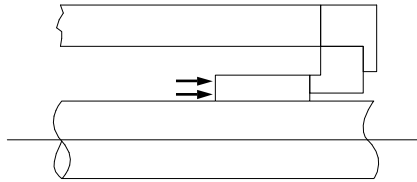
- Advantages of a single external seal are as follows:
  - easy to install and adjust as parts are readily accessible;
  - on abrasive or corrosive service, the seal parts are not rotating in liquid, thereby decreasing the chance of failure.

#### Double Seal

- The double seal consists of two single seals installed in the stuffing box (Figure 42).
- Advantages of using double seals are
  - for toxic or hazardous liquids where any leakage to the atmosphere would be dangerous
  - where there are extremely abrasive conditions
  - where there is a vacuum condition



**FIGURE 42. Double Seal**

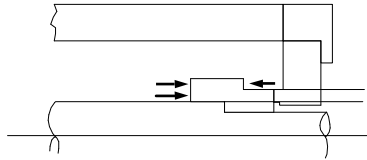


**FIGURE 43. Unbalanced Seal**

- With a double seal, provision must be made to introduce a clear liquid between the seals at a pressure higher than the suction pressure. The liquid is necessary to lubricate the seals and prevent heat buildup.

#### Unbalanced Seal

- The amount of pressure that an unbalanced seal (Figure 43) can accommodate is dependent upon the following:
  - shaft or sleeve diameter
  - shaft speed
  - face materials
  - the nature of the pumped product
- Along with the spring pressure, the stuffing box pressure that acts on the rotating member forces the faces together. However, because there is leakage of liquid across the faces, the pressure in the liquid forces the faces apart. The magnitude of this force is about half the liquid pressure in the stuffing box as it enters the face at box pressure and leaves at atmospheric pressure. This, in effect, creates a wedge-type force that pushes the faces apart.



**FIGURE 44. Balanced Seal**

- As the stuffing box pressure increases, the resulting pressure acting over the rotating sealing area becomes greater and the wedge force becomes less effective. This results in a film breakdown between the faces and little or no lubrication. Seal life may be shortened substantially.

#### Balanced Seal

- A balanced seal (Figure 44) is used when the application has either a high suction pressure or a liquid specific gravity of 0.7 or less.
- The sealing face pressure can be reduced by using the stuffing box pressure. For the seal configuration where the shaft is machined with a step or shoulder, the stuffing box and spring pressure act against the rotating member while the film wedge tends to force the faces apart.
- The face width may remain unchanged, although it is smaller in diameter. The difference is that the rotating member has equal pressure in both directions beyond the original shaft diameter, and there is hydraulic balance in this area.

Effective stuffing box pressure acts on the sealing portion within the machined step. Because there is little change in face area, the face pressure also reduces.

#### Seal Modifications

- Advantages of a mechanical seal
  - it is available with a number of modifications and arrangements. Most modifications are relatively inexpensive if furnished with the seal initially. Consideration must be given to special features when specifying the seal.
- Basic modifications that are available are listed below. They are not limited to extending the life of the seal, but also include safety features.
  - *Gland cooling* - helps to reduce the temperature of seal faces, which rises due to high temperature of product and/or frictional heat generated by the faces. This would be utilized on elevated temperature applications where there is a possibility of the liquid flashing at the seal surfaces. Should flashing occur, there would not be sufficient liquid for lubrication. Therefore, the faces would run dry and fail in a short period of time.
  - *Face lubrication* - may be used to lubricate the seal faces where there is a vacuum that tends to pull air across the faces. It is also used where the seal may run dry or for mildly abrasive conditions. By adding an outlet connection to the gland, lubricating liquid can also serve as a coolant by carrying heat away and preventing possible liquid flashing at seal faces.
  - *Flushing* - liquid is circulated through the stuffing box to carry heat away and prevent temperature rise and possible liquids flashing at seal faces. Flushing also prevents solids



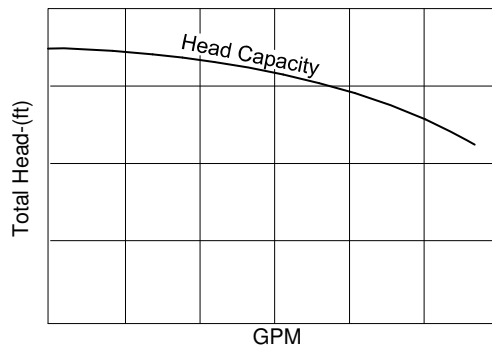
from settling out of suspension and prevents solidification in the box of liquids that might crystallize with a slight change in pumping temperatures. The flushing liquid may be the product pumped or a solvent liquid from an independent source.

- *Quenching* - utilized to cool the outside seal or remove any leakage that may crystallize on the faces when in contact with the air. On vacuum service, the quenching liquid acts as a lubricant and seal between the mated faces. If it were not used, air would be pulled across the faces with the result that they would run dry and fail.
- *Vent and drain* - a safety feature on internally mounted seals. It prevents liquid from spraying along the external portion of the shaft in the event of a seal failure.

#### BEARINGS

- The function of bearings in a centrifugal pump is to keep the rotating assembly in correct alignment with the stationary parts under the action of radial and axial loads. Those that give radial positioning to the rotator are known as *line bearings* and those that locate the rotor axially are called *thrust bearings*.
- All types of bearings are used in centrifugal pumps. Even the same basic design of pump is often manufactured with two or more different bearings to cover the requirements of varying service conditions. Two external bearings are normally utilized for the double-suction single-stage general service pump, one on either side of the casing.
- In horizontal pumps with bearings on each end, the inboard bearing is the one between the casing and the coupling, and the outboard bearing is located on the opposite end.

- Pumps with overhung impellers have both bearings on the same side of the casing; the bearing nearest the impeller is the inboard bearing and the one farthest away is the outboard bearing.
- Ball bearings are the most common antifriction bearing used on centrifugal pumps. Roller bearings are used less often although the spherical roller bearing is frequently used for large shaft sizes. Bearings are normally grease lubricated, although some services use oil lubrication, depending on design loads, speed, and service conditions.
- Sleeve bearings are used for large heavy-duty pumps with shaft diameters of such proportions that the necessary antifriction bearings are not readily available. Other applications include high pressure multistage pumps operating at speeds of 3,600 to 9,000 rpm and vertical submerged pumps such as vertical turbine pumps in which the bearings are subject to liquid contact. Most sleeve bearings are oil lubricated.



**FIGURE 45. Head-Capacity Curve**

- Thrust bearings used in combination with sleeve bearings are generally Kingsbury or similar-type bearings.

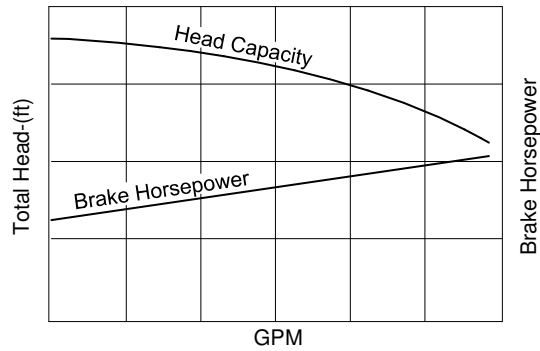
## CENTRIFUGAL PUMP PERFORMANCE

- The performance of a centrifugal pump is normally described in terms of the following characteristics:
  - rate of flow or capacity  $Q$ , expressed in units of volume per unit of time, most frequently gpm US or cfs (1 cfs = 440 gpm);
  - increase of energy content in the fluid pumped or head  $H$ , expressed in units of energy per unit mass usually ft per lb, or more simply, ft of liquid pumped;
  - input power BHP expressed in units of work per unit of time, horsepower;
  - efficiency  $E$ , the ratio of useful work performed to power input;
  - rotative speed  $N$  in rpm.
- Because the parameters indicated are all mutually interdependent, performance of a centrifugal pump is represented by characteristic curves. The section below will introduce the common characteristic curves in everyday use.

### PUMP RATING CURVES

#### *Head-capacity curve*

- Any centrifugal pump has a rating curve that indicates the relationship between the head developed by the pump and the flow through the pump for a particular speed, and for a particular diameter impeller when handling a liquid of negligible viscosity, usually water (Figure 45).



**FIGURE 46. Brake-Horsepower-Capacity Curve**

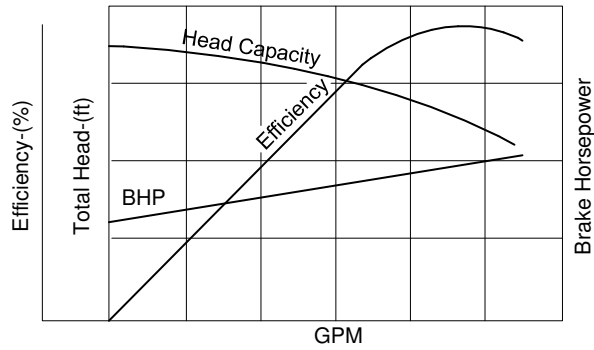
- As the capacity increases, the total head that the pump is capable of developing is reduced. In general, the highest head that a centrifugal pump can generate is developed at a point when there is no flow through the pump.

*Brake-horsepower-capacity curve*

- In order for the centrifugal pump to deliver the capacity that is required, it is necessary to provide the pump with a certain horsepower.
- A curve (Figure 46), which represents the relationship between brake horsepower and capacity, is plotted based on the same constant factors as outlined previously.

*Efficiency-capacity curve*

- Head-capacity curve and brake horsepower-capacity curve are determined by testing an actual pump for efficiency.



**FIGURE 47. Efficiency-Capacity Curve**

- The efficiency cannot be measured directly, but must be calculated from the measured information.
- The formula for efficiency is as follows:

$$E_p = \frac{H \times \text{gpm} \times \text{sp.gr.} \times 100}{3960 \times \text{BHP}}$$

where:

- $E_p$  = pump efficiency (%)
- $H$  = head developed by the pump (ft)
- $\text{gpm}$  = capacity delivered by pump (gpm US)
- $\text{sp.gr.}$  = specific gravity of liquid pumped
- $\text{BHP}$  = horsepower required by pump

- Using the above formula, the efficiency at which the pump is operating at any given capacity can be determined. The efficiency points are then plotted on the graph and the curve is generated (Figure 47).

### *Net Positive Suction Head (NPSH)-Capacity Curve*

- This curve is an important characteristic of a centrifugal pump and is always part of the pump's performance curves (Figure 48). It shows the relationship between the capacity that the pump will deliver and the NPSH that is required for proper operation of the pump at that capacity.
- Lack of the required amount of NPSH, measured in terms of feet of the pumped liquid, will cause the pump to cavitate with resultant noise, vibration, loss of efficiency, and reduction of life. The required NPSH data derived from an actual test is plotted on the graph, and the curve is generated.

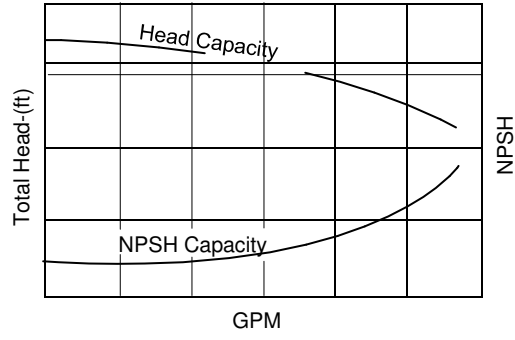
### *Overall rating curves*

- By plotting all of the above-mentioned characteristics on one coordinate system, the capabilities and limitations of a particular pump can be completely defined (Figure 49).

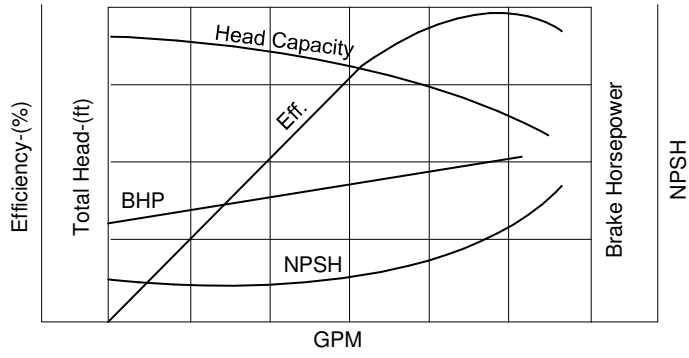
### PUMP SYSTEM CURVES

#### *Theoretical System*

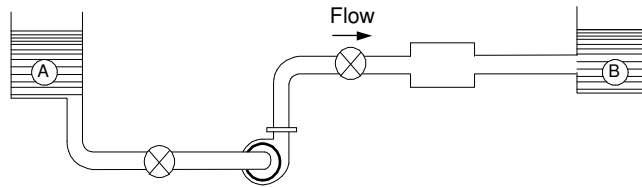
- Once the capability of the pump has been derived, consideration can be given to the requirements of the system in which the pump is installed. Figure 50 shows a very simple system.
- Point A and Point B are on the same level. Between Points A and B there is a pipe through which the liquid is propelled by the pump. In this pipe there are items such as valves, heat exchangers, and fittings that add to the total friction loss. Friction loss through the system will increase with an increase in capacity. In fact, the friction loss is proportional to the square of the capacity (or velocity).



**FIGURE 48. NPSH-Capacity Curve**



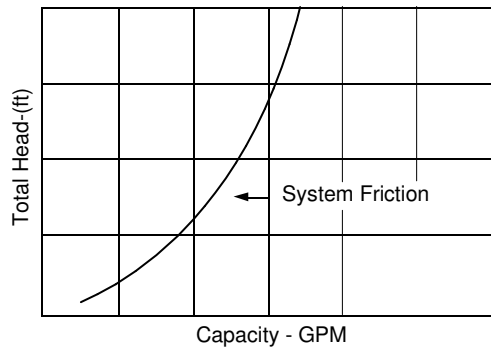
**FIGURE 49. Overall Rating Curves**



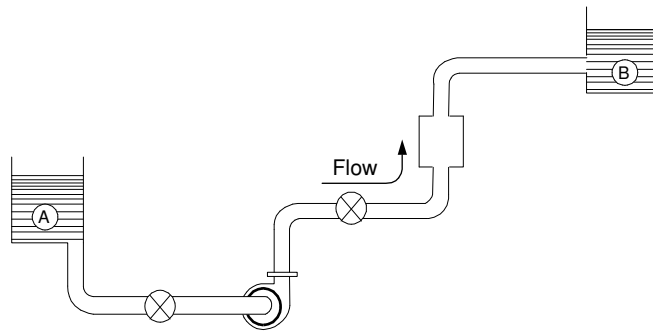
**FIGURE 50. Simple Pump System**

- The system curve can be plotted using the friction-loss data, expressed as feet of head, versus the capacity (Figure 51). At zero capacity there is no friction loss because there is no flow.
- Another factor can be introduced to complicate the above system; the same system is used, but Point B can be higher in elevation than Point A (Figure 52).
- Because Point B is higher than Point A, it is necessary to add extra energy to the liquid to transfer the liquid from Point A to Point B. The amount that must be added, expressed in feet of head, is exactly equal to the difference in elevation between Point B and Point A. However, the friction loss between Point A and Point B still has to be overcome. The new system is expressed by the curve shown in Figure 53.
- The friction curve is exactly the same because the friction loss between Point A and B is the same. A constant amount of energy (head) must be added at any capacity in order to get the liquid from the elevation at Point A to the elevation at Point B.

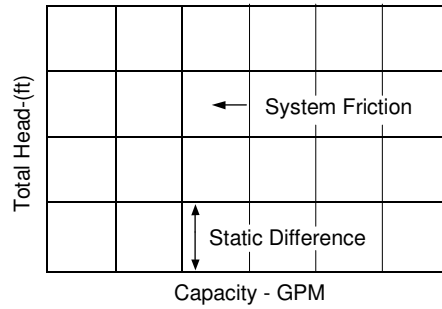




**FIGURE 51. System Curve of a Simple Pump System**



**FIGURE 52. Simple Pump System with a Difference in Elevation**

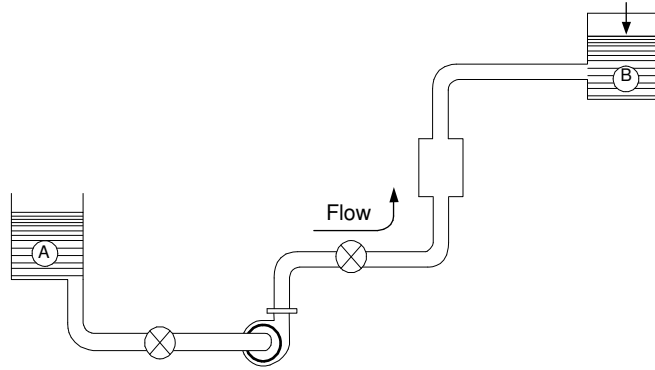


**FIGURE 53. System Curve of a Simple Pump System with an Elevation Difference**

- Another complication to the system can be introduced: the pressure at Point B can be greater than at Point A because Point B is a closed tank (Figure 54).
- Extra energy (head) must be added to the liquid to overcome the pressure differential between Point A and B. This can be seen on the system curve in Figure 55 as a movement of the system curve up the head ordinate.

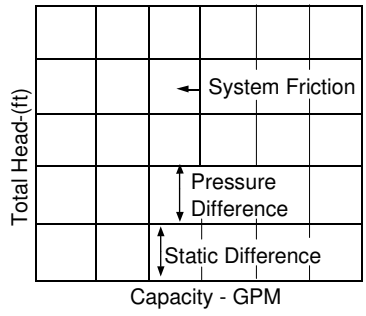
*Actual System*

- Figure 53 and 55 show the system curves that represent the requirement of the system for any flow rate.
- The parameters of the system are as follows:
  - the elevation difference between Point A and Point B is 50 feet
  - the frictional loss through the piping between Point A and B is 35 feet at 150 gpm US

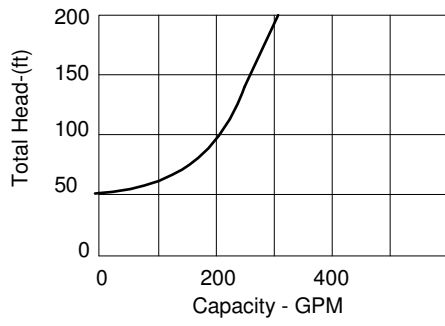


**FIGURE 54. Simple Pump System with a Difference in Elevation and Pressure**

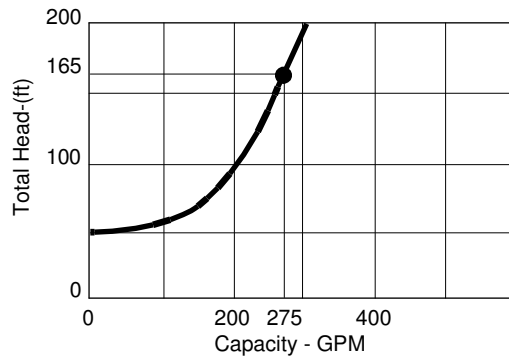
- If the capacity is doubled, the friction loss will be quadrupled. Consequently, the friction loss at 300 gpm will be 140 ft.
- The curve is plotted, and it represents the requirement of the system at any capacity between 0 and 300 gpm, with the friction loss being zero at zero flow. The curve is shown in Figure 56.
- The next task is to select a centrifugal pump to deliver the capacity of the requirement. In this example (Figure 57), the required pump delivery is 275 gpm.
- The system curve in Figure 55 shows that the pump is required to produce a 165 ft head at 275 gpm US. Using a pump manufacturer's manual, a pump that meets or exceeds these parameters is then selected. The selected pump generates 172 ft head at 275 gpm. The curve of the selected pump is now superimposed over the system curve (Figure 58).



**FIGURE 55. System Curve of a Simple Pump System with a Difference in Elevation and Pressure**

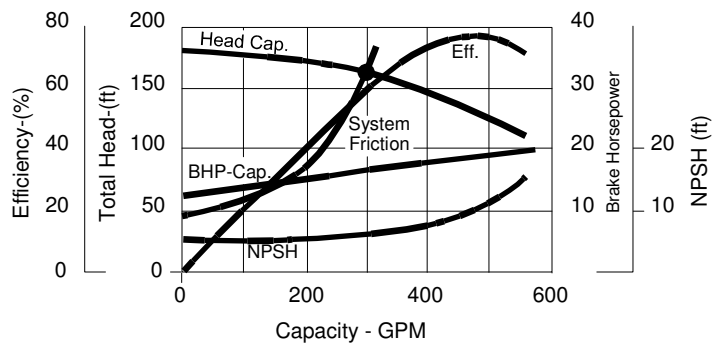


**FIGURE 56. System Curve**



**FIGURE 57. System Curve Indicating Required Pump Flow**

- The point of intersection between the pump's performance curve and the system requirement curve represents the capacity at which the pump will operate. **Note:** The capacity at which the pump operates in a system is the capacity derived by the intersection of the pump's performance curve and the system requirement curve.
- Because the pump operates at this capacity, the brake horsepower required by the pump to generate this capacity can be read. The NPSH required for proper operation of the pump at this capacity can therefore be obtained. **Note:** The brake horsepower is based on the specific gravity of 1.0. (water). If a higher or lower specific gravity liquid is being pumped, multiply the brake horsepower required for water by the actual specific gravity of the liquid. **Note:** Manufacturers' pump curves are rated with water, specific gravity 1.0
- The effect of variable friction loss in the system: a variable

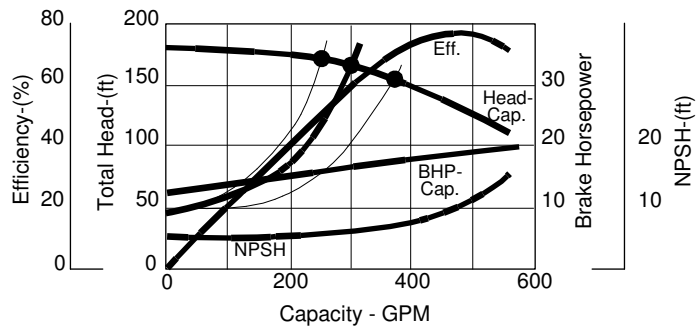


friction loss can be introduced, e.g., by a throttling valve that

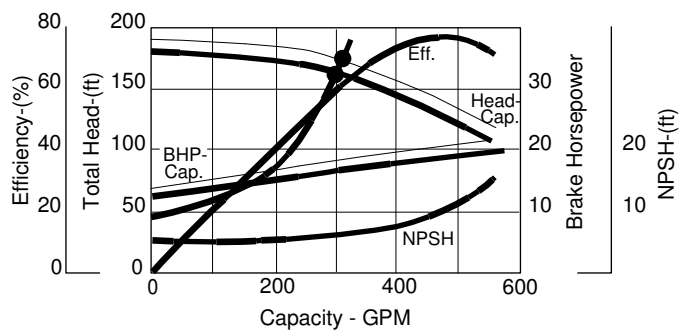
**FIGURE 58. Pump Curve Superimposed over System Curve**

may be manipulated during the pumping cycle. Using the system head curve generated previously, the new system head curve, shown in Figure 59, is represented by a dotted or dashed line. The dotted line indicates an increased friction loss, and the dashed line shows a decreased friction loss.

- The static head may also vary, e.g., when the suction receiver level and/or the discharge receiver level change. In this case, the whole system friction curve would move up or down as the pumping cycle progresses and the levels vary.
- Figure 60 shows the effect of using a pump that is capable of developing more head at a given capacity. The performance curve of the new pump is plotted as a dotted line.
- The new pump is capable of pumping more capacity in the system because the intersection of its performance curve is



at a greater capacity than the original intersection. **Note:** The dotted horsepower curve shows that a penalty is paid



**FIGURE 59. Effect of Variable Friction Loss**

## FIGURE 60. Effect of Varying Pump Head

for the increased head and capacity in the form of greater brake horsepower demand.

- **Conclusion:** The application of a centrifugal pump to a system is largely a matter of matching, as closely as possible, a particular pump with a specific system.
- The following key points should be remembered when analyzing a pumping system:
  - plot system friction curve;
  - plot pump's performance curve;
  - the results for BHP, NPSH, efficiency, and application.
- The system friction curve must be plotted when selecting a pump. Next, the pump's performance is plotted on the same coordinate system to ascertain how the pump will operate relative to the system. Arbitrary addition of excess capacity or head should be avoided as a safety factor. **Note:** In all of the above data, the speed of the pump, the impeller diameter, and the viscosity of the liquid was constant. In the following discussion, the effect of varying these parameters is considered.

### *Speed Changes*

- If the speed of the pump is doubled, the head developed by the pump is quadrupled because the head developed is proportional to the square of the velocity. However, when speed is changed, the capacity is also changed. When the operating speed is doubled, the capacity that the pump can handle is doubled. This doubling occurs because the liquid's velocity through the impeller has doubled.



- **For example:** If a pump that was capable of developing 50 ft total head at 100 gpm at 1750 rpm with a given impeller diameter was driven at 3500 rpm, it would develop 200 ft total head at a capacity of 200 gpm. However, utilizing the formula relating head, capacity, efficiency, and brake horsepower (assuming no efficiency change), it can be seen that the horsepower increases by a factor of eight when the speed of the pump is doubled.
- For this reason, a centrifugal pump cannot arbitrarily be sped up. This speed conversion is used in reducing the pump speed.
- To assess the pump's performance, the following relationships are utilized (efficiency is assumed to remain constant).

-For a given pump and impeller diameter:

$$\frac{N1}{N2} = \frac{Q1}{Q2} = \sqrt[3]{\frac{Hd1}{Hd2}} = \sqrt[3]{\frac{BHP1}{BHP2}}$$

or expressed differently:

$$\frac{N1}{N2} = \frac{Q1}{Q2} \quad \left(\frac{N1}{N2}\right)^2 = \frac{Hd1}{Hd2} \quad \left(\frac{N1}{N2}\right)^3 = \frac{BHP1}{BHP2}$$

where:

N = rotative speed, (rpm)

Q = flow, (gpm US)

Hd = head, (ft)

BHP = brake horsepower

1 = original parameter

2 = changed parameter

- **Note:** A revision in speed always results in a revision in capacity, head, and horsepower. All these items change simultaneously. The above formula gives an approximation of the final performance of the pump since efficiency change also slightly.

*Impeller Diameter Changes*

- The applicable formula for the change in capacity, head, and horsepower looks the same as those for change in speed. The relationships are expressed as follows:

-For a given pump and speed:

$$\frac{Dia.1}{Dia.2} = \frac{Q1}{Q2} = \sqrt{\frac{Hd1}{Hd2}} = \sqrt{\frac{BHP1}{BHP2}}$$

or expressed in a different way:

$$\frac{Dia.1}{Dia.2} = \frac{Q1}{Q2} \quad \left( \frac{Dia.1}{Dia.2} \right)^2 = \frac{Hd1}{Hd2} \quad \left( \frac{Dia.1}{Dia.2} \right)^3 = \frac{BHP1}{BHP2}$$

where:

Dia. = impeller diameter, (in.)

Q = flow, (gpm US)

Hd = head, (ft.)

BHP = brake horsepower

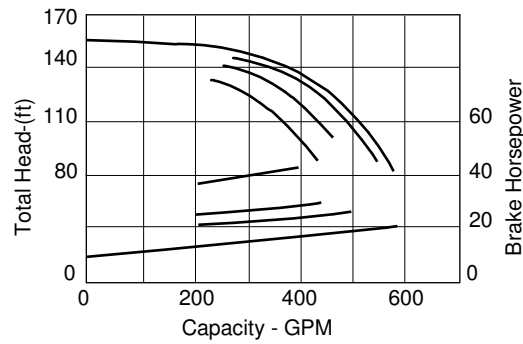
1 = original parameter

2 = changed parameter

- The above formulae are acceptable for small changes of impeller diameter, but should not be used when the impeller diameter changes more than 10%. Because when the impeller diameter in a pump is changed, the basic relationship between the impeller and the casing is altered. Thus the design configuration is also changed.
- **Note:** The answers obtained from the calculations are not accurate enough to select an actual impeller diameter without first checking the rating curves to determine if the pump has been tested with that particular impeller diameter.

*Effect of Viscosity*

- A change in viscosity can affect the performance of a centrifugal pump significantly. The performance of a pump (when the viscosity of the liquid is progressively increased) is shown in Figure 61.



**FIGURE 61. Effect of Viscosity Increase**

- **Note:** The head-capacity curve drops off as the viscosity increases, and the brake horsepower demand increases sharply. The pump manufacturer has correction curves that enable the prediction of a particular pump's performance when handling viscous liquids.

## CENTRIFUGAL PUMP APPLICATIONS

- The following is not meant to be a complete list of centrifugal pump applications, but an illustration the versatility of this type of pump.
- Water Supply
  - low-lift pumps
  - sampling pumps
  - wash water pumps
  - high-service pumps
  - booster pumps
- Ground Water Wells
  - vertical turbine lineshaft pump
  - submergible pump
- Sewage Treatment
  - raw sewage pump
  - settled sewage pump
  - service water pump
  - dilute sludge and scum pump
- Drainage and Irrigation
  - deep well turbine pump
  - submergible turbine pump

- propeller pumps
- volute pumps
- Fire Pumps
  - vertical turbine pump
  - horizontal volute pump
- Steam Power Plants
  - condensate pumps
  - heater drain pumps
  - condenser circulating pumps
  - boiler circulating pumps
  - ash-handling pumps
- Petroleum
  - crude distillation pumps
  - vacuum tower separation pumps
  - catalytic conversion pumps
  - alkylation pumps
  - hydro cracking pumps
  - coking pumps
  - pipeline pumps
- Pulp and Paper Mills
  - heavy-black-liquid pumps
  - digester-circulating pumps
  - low- and intermediate-concentration stock pumps
- Mining
  - All applications for open pit and deep mines including control of seepage, rainwater, and service water.

- Food and Beverage
  - used throughout the industry except when metering is required or when high viscosities such as dough or cottage cheese must be handled.
  
- Refrigeration, Heating, and Air Conditioning
  - cooler tower water circulating pumps
  - hot water circulating pumps
  - brine circulation pumps
  - refrigerant circulation pumps

# ROTARY PUMPS:

*Principles, Components, Performance*

- A rotary pump is a positive displacement machine.
- It traps liquid, forces it around the casing, and expels it through the discharge instead of spinning out the liquid as a centrifugal pump does.
- It discharges a smooth flow of liquid unlike the positive displacement reciprocating pump.
- These pumps are characterized by their close running clearances.
- Most rotary pump designs do not incorporate the use of valves or complicated waterways. This allows the pump to be quite efficient on both low- and high-viscosity liquids

with low NPSH requirements. Rotary pumps are not limited to use on viscous liquids. Any liquid with a reasonable lubricity can be pumped if there are no abrasive solids present. Abrasive liquids can be handled with a penalty of greatly reduced pump life.

## OPERATING PRINCIPLES

- The pumping sequence of all rotary pumps includes three elementary actions
  - the rotating and stationary parts of the pump act to define a volume, sealed from the pump outlet, and open to the pump inlet.
  - the pump elements establish a seal between the pump inlet and some of this volume, and there is a time when this volume is not open to either the inlet or the outlet parts of the pump chamber.
  - the seal to the outlet part is opened, and the volume open to the outlet is constricted by the cooperative action of the moving and stationary elements of the pump.
- In all types of rotary pumps, the action of the pumping volume elements must include these three conditions
  - closed to outlet, open to inlet
  - closed to outlet, closed to inlet
  - open to outlet, closed to inlet
- **Note:** At no time should any liquid in the pumping chamber be open to both inlet and outlet ports simultaneously if the pump is truly a positive displacement pump.



## COMPONENTS OF A ROTARY PUMP

- The rotary pump consists of the following parts:
  - pumping chamber
  - body
  - endplates
  - rotating assembly
  - seals
  - bearings
  - timing gears
  - relief valves

### PUMPING CHAMBER

- The pumping chamber is defined as all the space inside the pump that contains the pumped liquid while the pump is in operation. Liquids enter the chamber through one or more inlet ports and leave through one or more outlet ports.

### BODY

- The body is that part of the pump that surrounds the boundaries of the pumping chamber and is sometimes called a *casing* or *housing*.

### ENDPLATES

- The endplates are those parts of the body or separate parts that close the ends of the body to form the pumping chamber. They are sometimes called *pump covers*.

### ROTATING ASSEMBLY

- The rotating assembly generally includes all the parts of the pump that rotate when the pump is operating. The rotor is

the specific part of the rotating assembly that rotates within the pumping chamber. Rotors may be given names in specific types of rotary pumps such as gears, screws, and lobes. The drive shaft transfers the torque and speed from the prime mover to the rotor.

#### SEALS

- The pump seals are of two types: static and dynamic.
- Static seals provide a liquid-tight and airtight seal between removable stationary parts of the pumping chamber.
- Dynamic seals are used at the pumping chamber boundary locations through which moving elements, usually shafts, extend.

#### BEARINGS

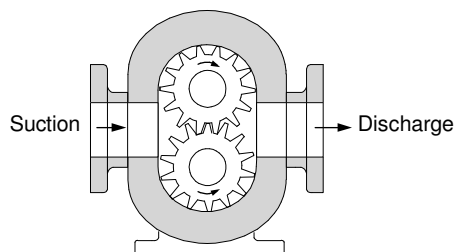
- The bearings can be ball, roller, thrust, or sleeve type.
- Internal wet bed by liquid or external.

#### TIMING GEARS

- In multiple rotor pumps, torque is transmitted to the rotors and the angular relationship between them that is maintained by timing gears.

#### RELIEF VALVES

- The pressure at the outlet port can become damagingly high if the pump discharge is obstructed or blocked.



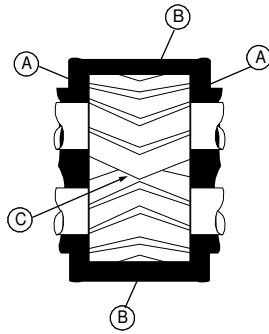
**FIGURE 62. External Gear Pump**

Source: *Pumping Manual*, 6th ed. Trade and Technical Press, 1979.

- Relief valves are used to limit the pressure, thereby opening an auxiliary passage at a predetermined pressure that will prevent catastrophic failure of the pump casing. The valve may be integral with the body, endplate, or separate mounted.

## ROTARY PUMP PERFORMANCE

- The performance characteristics of a rotary pump are subservient to many independent factors. The most important of these factors is called *slip*.
- Theoretically, each revolution of the drive shaft of a rotary pump displaces the same quantity of liquid regardless of changes in the head. This quantity is called *displacement*. Using an external gear pump as shown in Figure 62, for example, displacement is the sum of the volumes between all the spaces between the gear teeth (both gears).
- The pump has 28 spaces (valleys) between its gear teeth; therefore, its displacement in one revolution is equal to the space between two teeth multiplied by 28. In actual practice, theoretical displacement is seldom achieved. Clearance must

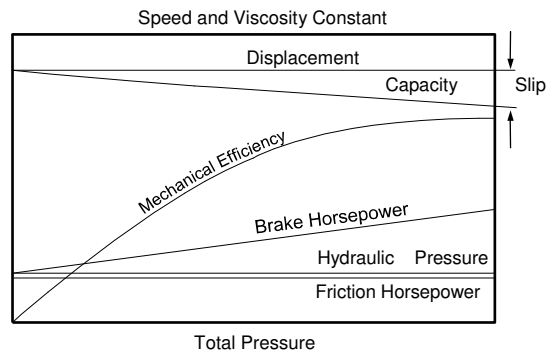


**FIGURE 63. Slippage Areas**

Source: *Pumping Manual*, 6th ed. Trade and Technical Press, 1979.

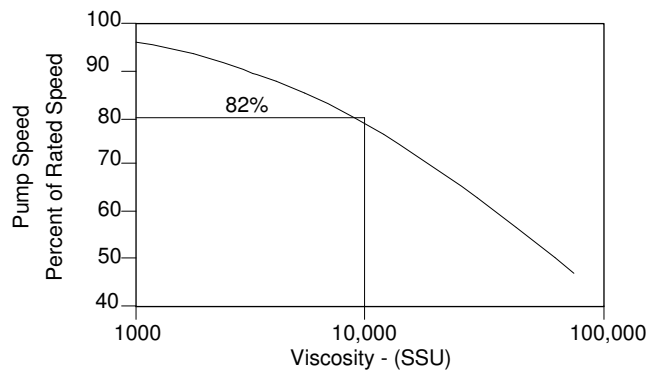
be provided between the pumping element and the casing because the rotating parts have to be lubricated. The small quantity of liquid that leaks through these clearances from the discharge side to the suction side is referred to as *slip*.

- The areas where slippage occurs on a typical external gear pump are illustrated in Figure 63.
- Slippage takes place in three areas
  - between the sides of the gears and sideplates(A)
  - between the gears and the body (B)
  - between the gears themselves(C)
- The rotary pump is a positive displacement device. Therefore, the theoretical displacement of this pump is a straight horizontal line when plotted against total pressure with speed a constant. There is no variation in displacement as head varies as in a centrifugal pump.



**FIGURE 64. Relationships of Performance Terms**

- Figure 64 shows the graphical relationships of the terms that are being used in denoting pump performance.
- When handling low-viscosity liquids, there is a loss in pump delivery due to slip, which increases with pressure. The actual pump capacity at any particular speed and viscosity is the difference between the theoretical displacement and slip.
- Viscosity, pressure, clearances, and speed are the major factors that influence slip.
- Viscosity is defined as a liquid's resistance to flow. It is apparent that the higher the viscosity of a liquid, the less tendency it has to slip. The opposite is true with low-viscosity liquids: the lower the viscosity, the greater the tendency to slip.



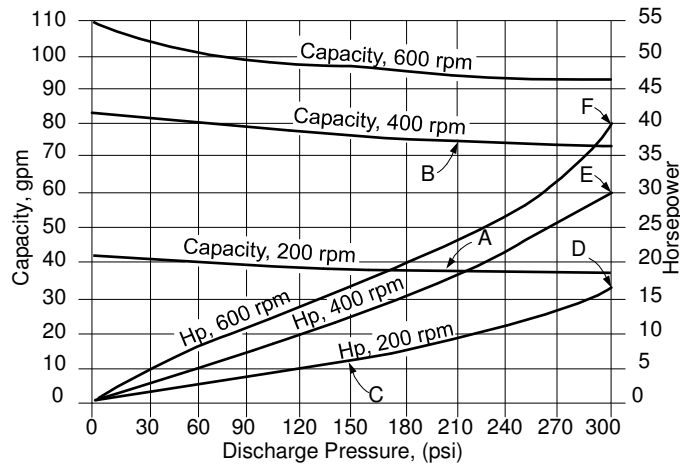
**FIGURE 65. Pump Speed/Viscosity Relationship**

Source: *Pumping Manual*, 6th ed. Trade and Technical Press, 1979.

- Viscosity is also interdependent upon speed: as viscosity is increased, flow slows down. Thus the speed of the pump must be reduced so that the spaces between the gear teeth can be completely filled.
- Figure 65 shows the relationship between pump speed and viscosity.
- As viscosity increases, the capacity curve (see Figure 64) approaches the theoretical displacement until, at a viscosity based on design, there is no measurable slip, and capacity equals displacement. In an external gear pump, minimal slip occurs at a liquid viscosity of approximately 5,000 Saybolt Second Units (SSU).
- As discharge pressure increases, the differential pressure between the discharge and suction side becomes even

greater. This results in an increasingly greater slip from the high pressure to the low pressure side.

- As mentioned previously, clearances must be present for lubrication. Actually, most commercially built rotary pumps are a compromise. If a pump were designed for high viscosity liquids, clearances could be quite liberal without causing an appreciable slip or loss of capacity. For low viscosity liquids, tight clearances would have to be held to avoid excessive slip and loss in capacity. Because most rotary pumps are sold for a wide range of viscosities, clearances must be close enough to offer a reasonably high volumetric efficiency (usually 80% to 100% through the viscosity range of the pump) when handling “thin” liquids and yet be liberal enough to allow lubrication when high viscosity liquids are pumped.
- Figure 64 shows that brake horsepower is also a straight-line function. At zero pressure, there is still a definite horsepower requirement due to friction in the pump. This friction horsepower does not vary appreciably with increased pressure and is a result of internal friction of bearings, stuffing box (or seal), and meshing of rotors. The other component of brake horsepower is usually referred to as hydraulic (or water) horsepower and is directly proportional to the amount of work the pump does. (i.e., capacity, mechanical friction, and viscous horsepower make up the pump-required input power.)
- Viscosity also affects pump capacity, running speed, power requirements, and efficiency. Figure 66 indicates performance of a rotary pump at different speeds with viscosity kept constant.



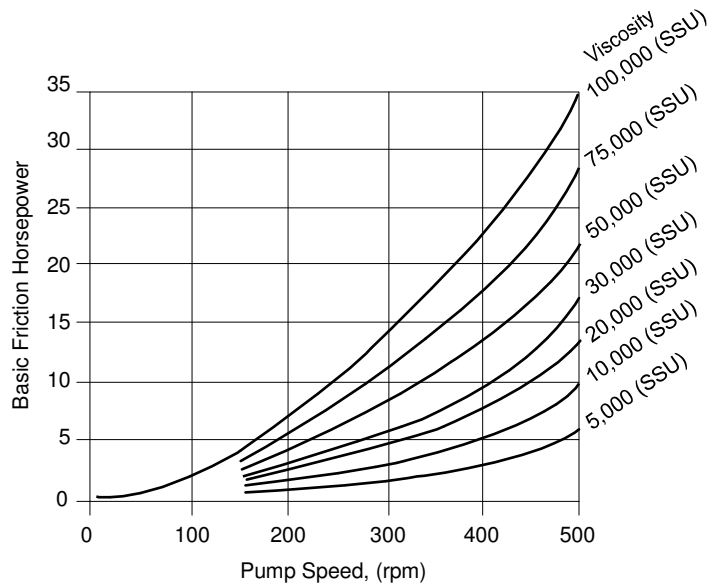
**FIGURE 66. Pump Performance at Different Speeds with Viscosity Constant**

Source: *Pumping Manual*, 6th ed. Trade and Technical Press, 1979.

- The capacity curves at different speeds are nearly parallel, thereby showing similar losses in capacity as pressure increases. The pump capacity of 75 gpm at 210 psi and 400 rpm (Point B) is approximately double the capacity at 200 rpm (Point A).
- Above 400 rpm, the liquid's viscosity begins to have an effect and the pump's capacity does not increase directly as the speed does. Because the suction pressure was too low for the higher speed, the viscous liquid does not flow quickly enough into the pump to keep it full at 600 rpm. As a result, pump capacity increases only about one-half as much from 400 to 600 rpm as it did from 200 to 400 rpm. The brake horsepower also increases in proportion.



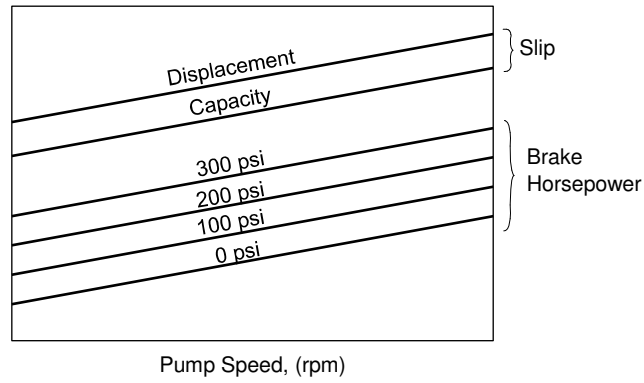
- **For example:** At 150 psi and 200 rpm, the pump requires about 6.5 hp to drive it (Point C). At 300 psi and 200 rpm, power increases to about 15 hp (Point D), while nearly 30 hp (Point E). but from 400 to 600 rpm (Point F), power increases less than 10 hp because of the slower rate at which pump capacity increased.
- Power required to drive the pump increases with viscosity as shown in Figure 67. The power shown on the curve is called *basic friction horsepower*. This power represents only that used to cause the liquid to flow through the pump. It does not include the power required to overcome the system's external head.
- Rotary pumps can have efficiencies as high as 80% to 85% when handling relatively high viscosities (10,000 to 15,000 SSU). As the viscosity increases, the efficiency will fall off slightly, but careful selection can result in high efficiencies and appreciable power savings over a period of time.
- The performance curve that has been used up to this point, while indicative of rotary pump performance at a specified speed and viscosity, is not practical for pump selection. Since these pumps can be operated over a very wide range of speeds, it is much more practical to show performance as displayed in Figure 68.
- Performance, both capacity and brake horsepower, are plotted against pump rpm. Actual capacities with slip taken into account are shown as parallel lines at different pressures. Viscosity is kept constant.



**FIGURE 67. Effect of Viscosity Increase on Horsepower**

Source: *Pumping Manual*, 6th ed. Trade and Technical Press, 1979.

- Maximum speed limits are usually based on an attempt to have the pump fill properly. This occurrence is tied directly to NPSH since high static suction lifts, long suction lines with high friction loss and high viscosity fluids all tend to reduce the available NPSH of the system. When the liquid does not have enough energy to fill all of the displacement spaces between the rotors and the casing, partial vaporization of the liquid takes place, causing a loss in capacity, and an increase in noise level. This is particularly true with high viscosity fluids: thus, as viscosity increases, the maximum allowable rpm is decreased.



**FIGURE 68. Rotary Pump Performance**

- Due to the self-priming characteristic of this pump, the rotary pump is operated at impossible suction conditions. On non-volatile liquids, it is possible to operate a rotary pump at vacuums as high as 28 inches of mercury. Many petroleum products will contain light fractions (ethers) that will reduce pump capacity appreciably at high vacuums. Entrained or dissolved air, particularly in oils that have a great affinity for air, will appreciably reduce pump capacity at high vacuum conditions.
- **For example:** 5% entrained air at normal atmospheric conditions will expand in the suction line so that at 25 inches of mercury vacuum, the entrained air will represent as much as 35% of the pump capacity.

## ROTARY PUMP APPLICATIONS

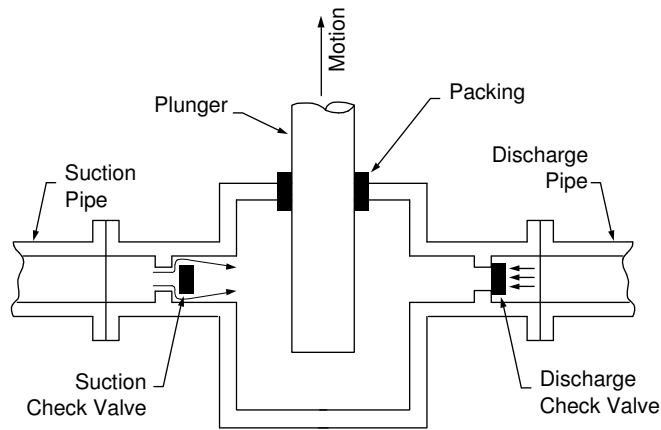
- Typical applications include.
- Refrigeration Heating and Air Conditioning
  - lubricating oil transfer pump
- Food Beverage
  - lobe-type, flexible-vane or screw pump used for high viscosity or metering
- Pulp and Paper
  - screw-type pump used for high density stock
- Chemical
  - Transfer and metering of chemicals
- Sewage Treatment
  - screw-type pump used for concentrated sludge and scum
- Manufacturing
  - hydraulic pumps for numerous applications
- Water Supply
  - carbon slurry pump

# RECIPROCATING PUMPS:

*Principles, Components, Performance*

## OPERATING PRINCIPLES

- A reciprocating positive displacement pump is one in which a plunger or piston displaces a given volume of fluid for each stroke.
- All reciprocating pumps have a fluid-handling portion commonly called the *liquid end*, which has the following components (Figure 69):
  - a displacing solid called a *plunger* or *piston*;
  - a container to hold the liquid called the liquid cylinder;
  - a suction check valve to admit fluid from the suction pipe into the liquid cylinder;
  - a discharge check valve to admit flow from the *liquid cylinder* into the discharge pipe;
  - packing to seal tightly the joint between the plunger and the liquid cylinder to prevent the liquid from leaking out of the cylinder, and air from leaking into the cylinder.

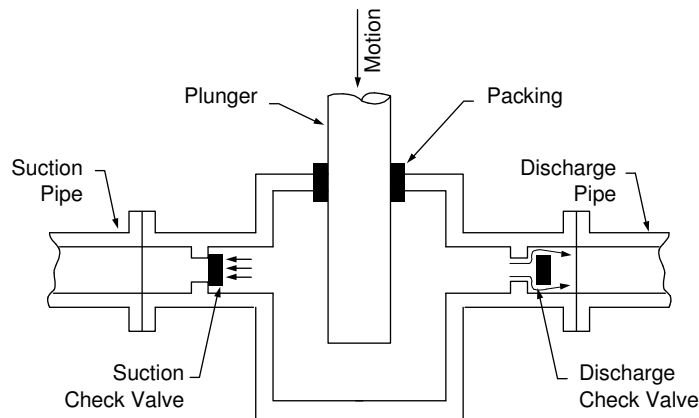


**FIGURE 69. Liquid End of a Reciprocating Pump During the Suction Stroke**

Reproduced with permission of McGraw-Hill from Karassik, I. J. (ed).  
*Pump Handbook*, 2nd ed., 1986.

- To pump liquid, the following sequence of events occurs:
  - where the plunger is moved out of the liquid cylinder, the pressure of the liquid within the cylinder is reduced.
  - when the pressure becomes less than in the suction pipe, the suction check valve opens, and the liquid flows into the cylinder to fill the volume being vacated by withdrawal of the plunger. During this phase of the operation, the discharge check valve is held closed by the higher pressure in the discharge pipe. This portion of the pumping action is called the *suction stroke*.
  - the withdrawal movement must be stopped before the end of the plunger gets to the packing. The plunger movement is then reversed and the discharge stroke portion of the pumping action is started (Figure 70).

- Pumping cycle of a single-acting reciprocating pump:
  - it is called *single-acting* because it makes only one discharge stroke in one cycle.
  - movement of the plunger into the liquid cylinder causes an immediate increase in pressure of the liquid contained therein. This pressure becomes higher than suction pipe pressure and causes the suction check valve to close.
  - with further plunger movement, the liquid pressure continues to rise. When the liquid pressure attains that in the discharge pipe, the discharge check valve is forced open, and liquid flows into the discharge pipe. The volume forced into the discharge pipe is equal to the plunger



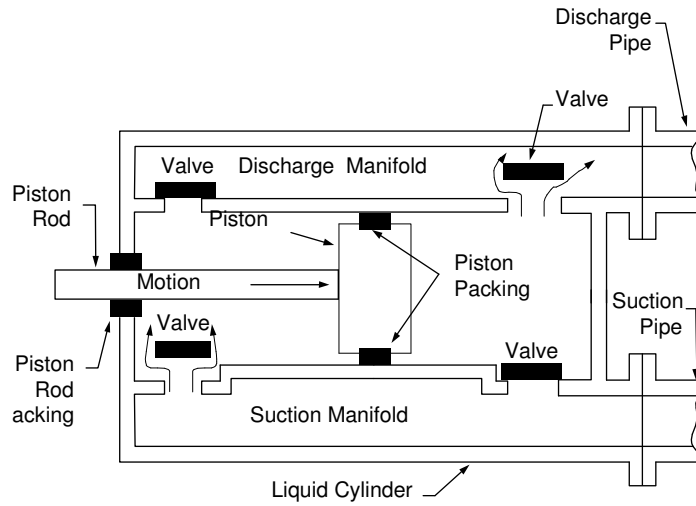
**FIGURE 70. Liquid End of a Reciprocating Pump During the Discharge Stroke**

Reproduced with permission of McGraw-Hill from Karassik, I. J. (ed).  
*Pump Handbook*, 2nd ed., 1986.

displacement less small losses. The plunger displacement is the product of its cross-sectional area multiplied by the length of the stroke. The plunger must be stopped before it impacts on the bottom of the liquid cylinder. The motion of the plunger is then reversed, and the plunger proceeds to the suction stroke.

- Many reciprocating pumps are double-acting, i.e., they make two suction and two discharge strokes for one reciprocating cycle. Most double-acting pumps use a piston, which as a displacing solid is sealed to a bore within the liquid cylinder. Figure 71 shows a double-acting liquid end.
- Double-acting pumps have also two suction and two discharge check valves, one of each on either end of the piston. The piston is moved by a piston rod. The piston rod seal (packing) prevents liquid from leaking out of the cylinder. When the piston is moved in the direction shown, the right side of the piston is on a discharge stroke and the left side of the piston is simultaneously on a suction stroke. The piston seal must seal tightly to the cylinder liner to prevent leakage of liquid from the high pressure right side to the low pressure left side. The piston must be stopped before it hits the right side of the cylinder. The motion of the piston is then reversed so the left side of the piston becomes the discharge stroke and the right begins the suction stroke.
- A reciprocating pump must have a driving mechanism to provide motion and force to the piston. The two most common driving mechanisms are a reciprocating steam engine and a crank and throw device. Pumps that use the steam engine are called *direct-acting steam pumps*. Pumps that use the crank and throw device are called *power pumps*.





**FIGURE 71. Double-Acting Liquid End**

Reproduced with permission of McGraw-Hill from Karassik, I. J. (ed).  
*Pump Handbook*, 2nd ed., 1986.

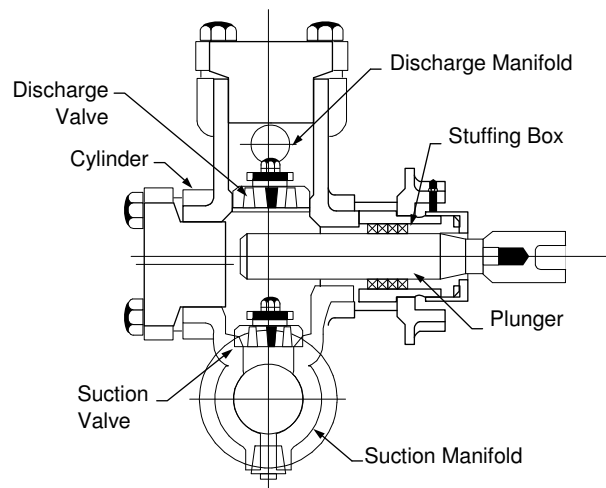
Power pumps must be connected to an external prime mover such as an electric motor, steam turbine, or internal combustion engine.

## COMPONENTS OF A POWER PUMP

- The subsequent data is a description of the fluid and power end components of a power pump.

### LIQUID END

- The liquid end comprises the cylinder, plunger or piston, stuffing box, check valves, and manifolds (Figure 72).



**FIGURE 72. Liquid End of a Horizontal Power Pump**

Reproduced with permission of McGraw-Hill from Karassik, I. J. (ed).  
*Pump Handbook*, 2nd ed., 1986.

### *Cylinder*

- The cylinder is the container where the pressure is developed. Cylinders on many horizontal pumps have the suction and discharge manifolds made integral with the cylinder. Vertical pumps usually have separate manifolds.

### *Plunger and Piston*

- The plunger or piston transmits the force that develops the pressure. Pistons are used for liquid pressures up to 1,000 psi. For higher pressures, a plunger is usually used. (typical range 1,000 to 30,000 psi)

### *Stuffing Box*

- The stuffing box prevents the plunger or the piston rod from leaking liquid to atmosphere, or allowing air to enter the liquid end of the pump. It consists of a casing, upper and lower bushing, packing, and gland.

### *Check Valves*

- These valves, dependent on the stroke of the plunger or piston, either allow liquid to flow through or halt the entering or leaving the liquid end of the pump. There are many types of valves; their use is dependent on the application.
- The main parts of the valves are the seat and the plate. The plate movement is controlled by a spring or retainer. The seat normally utilizes a taper where it fits into the cylinder or manifold. The taper not only gives a positive fit, but also allows easy interchangeability of the seat.
- Figure 73 shows various check valves with their application.

### *Manifolds*

- Manifolds are the chambers where liquid is dispersed or collected for distribution before or after passing through the cylinder. On horizontal pumps, the suction and discharge manifold is usually made integral with the cylinder. Most vertical pumps have the suction and discharge manifold separate from the cylinder.

### POWER END

- The power end comprises the crankshaft, connecting rod, crosshead, pony rod, bearings, and frame (Figure 74).

TYPE	SKETCH	PRESSURE	APPLICATION
Plate	<p>A=Seat Area B=Spill Area</p>	5,000	Clean fluid. Plate is metal or plastic.
Wing		10,000	Clean fluids, Chemicals
Ball		30,000	Fluids with particles. Clear, clean fluid at high pressure. Ball is chrome plated.
Plug		6,000	Chemicals
Slurry		2,5000	Mud, slurry. Pot dimensions to API-12. Polyurethane or Buna-N insert

**FIGURE 73. Types of Check Valves**

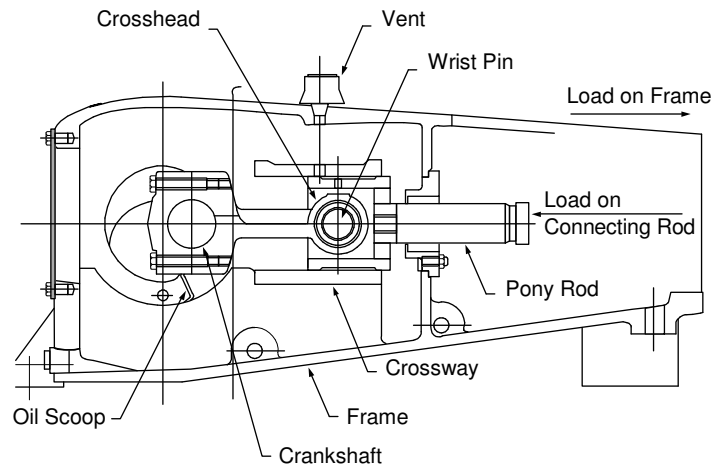
Reproduced with permission of McGraw-Hill from Karassik, I. J. (ed).  
*Pump Handbook*, 2nd ed., 1986.

### *Crankshaft*

- The crankshaft provides the method of obtaining oscillating motion on the plunger. An eccentric offset equivalent to one half the required stroke is cast into this component. The connecting rod is affixed to this offset and transfers the power.

### *Connecting Rod*

- The connecting rod transfers the rotating force of the crankshaft to an oscillating force on the wrist pin. Connecting rods are split perpendicular to their center line at the crankpin end for assembly of the rod onto the crankshaft.



**FIGURE 74. Power End of a Horizontal Power Pump**

Reproduced with permission of McGraw-Hill from Karassik, I. J. (ed).  
*Pump Handbook*, 2nd ed., 1986.

### *Crosshead*

- The crosshead moves in a reciprocating motion and transfers the plunger load to the wrist pin. The crosshead is designed to absorb the radial load from the plunger as it moves linearly on the crossway.

### *Bearings*

- Both sleeve and anti-friction bearings are used in power pumps. Some frames use all sleeve, others use all anti-friction, and still others use a combination of both types of bearings.

### *Frame*

- The frame absorbs the plunger load and torque. On vertical pumps with an outboard stuffing box, the frame is in compression. With horizontal single-acting pumps, the frame is in tension.

## RECIPROCATING PUMP PERFORMANCE

- The following data will outline the main terms involved in determining the performance of a reciprocating pump. Figure 75 shows a typical performance curve.

### MAIN TERMS

#### *Brake Horsepower (BHP)*

- Brake horsepower is the actual power required at the pump input shaft in order to achieve the desired pressure and flow. It is defined as the following formula:

$$BHP = \frac{Q \times Pd}{1714 \times Em}$$

where:

BHP = brake horsepower

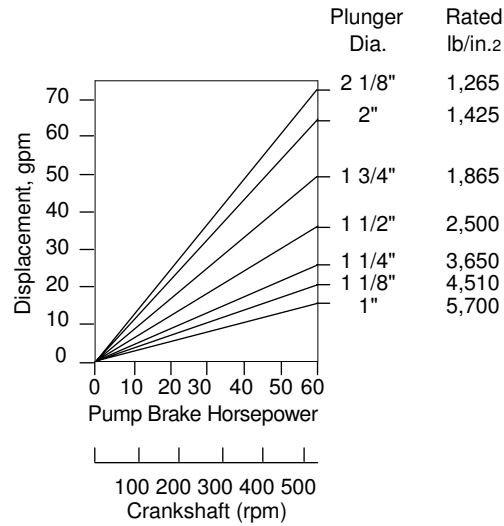
Q = delivered capacity, (gpm US)

Pd = developed pressure, (psi)

Em = mechanical efficiency, (% as a decimal)

*Capacity (Q)*

- The capacity is the total volume of liquid delivered per unit of time. This liquid includes entrained gases and solids at specified conditions.



**FIGURE 75. Reciprocating Pump Performance Curve**

Reproduced with permission of McGraw-Hill from Karassik, I. J. (ed).  
*Pump Handbook*, 2nd ed., 1986.

*Pressure (Pd)*

- The pressure used to determine brake horsepower is the differential developed pressure. Because the suction pressure is usually small relative to the discharge pressure, discharge pressure is used in lieu of differential pressure.

*Mechanical Efficiency (Em)*

- The mechanical efficiency of a power pump at full load pressure and speed is 90 to 95% depending on the size, speed, and construction.

*Displacement (D)*

- Displacement (gpm) is the calculated capacity of the pump with no slip losses. For single-acting plunger or piston pumps, it is defined as the following:

$$D = \frac{AMns}{231}$$

where:

D = displacement, (gpm US)

A = cross-sectional area of plunger or piston, (in<sup>2</sup>)

M = number of plungers or pistons

n = speed of pump, (rpm)

s = stroke of pump, (in.) (half the linear distance the plunger or piston moves linearly in one revolution)

231 = constant (in<sup>3</sup>/gal)

- For double-acting piston pumps, the above is modified as follows:

$$D = \frac{(2A_s)Mns}{231}$$



where:

$a$  = cross-sectional area of the piston rod, (in<sup>2</sup>)

*Slip(s)*

- Slip is the capacity loss as a fraction or percentage of the suction capacity. It consists of stuffing box loss  $B_L$  plus valve loss  $V_L$ . However, stuffing box loss is usually considered negligible.

*Valve Loss ( $V_L$ )*

- Valve loss is the flow of liquid going back through the valve while it is closing and/or seated. This is a 2% to 10% loss depending on the valve design or condition.

*Speed ( $n$ )*

- Design speed of a power pump is usually between 300 to 800 rpm depending on the capacity, size, and horsepower. To maintain good packing life, speed is limited to a plunger velocity of 140 to 150 ft/minute. Pump speed is also limited by valve life and allowable suction conditions.

*Number of Plungers or Pistons ( $M$ )*

- Table 1 shows the industry's terminology for the number of plungers or pistons on the crankshaft. The terminology is the same for single- or double-acting pumps.

*Pulsations*

- The pulsating characteristics of the output of a power pump are extremely important in pump application. The magnitude of the discharge pulsation is mostly affected by the number of plungers or pistons on the crankshaft.

Table 2 illustrates the variations in capacity related to the number of plungers or pistons in the pump.

**TABLE 1. Terminology for the Number of Plungers/Pistons on the Crankshaft**

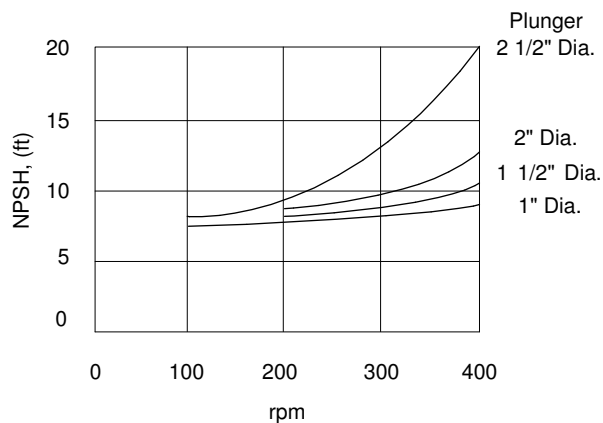
<b>Number of Plungers/Pistons</b>	<b>Term</b>
1	Simplex
2	Duplex
3	Triplex
4	Quadruplex
5	Quintuplex
6	Sextuplex
7	Septuplex
9	Nonuplex

**TABLE 2. Effect of Number of Plungers on Variations from the Mean**

<b>Type</b>	<b>Number of Plungers</b>	<b>% Above Mean</b>	<b>% Below Mean</b>	<b>Total %</b>	<b>Plunger Phase</b>
Duplex (double)	2	24	22	46	180°
Triplex	3	6	17	23	120°
Quadruplex	4	11	22	33	90°
Quintuplex	5	2	5	7	72°
Sextuplex	6	5	9	14	60°
Septuplex	7	1	3	4	51.5°
Nonuplex	9	1	2	3	40°

### Net Positive Suction Head Required (NPSHR)

- The NPSHR is the head of clean clear liquid required at the suction centerline to ensure proper pump suction operating conditions. For any given plunger size, rotating speed, pumping capacity, and pressure, there is a specific value of NPSHR. A change in one or more of these variables changes the NPSHR.
- It is a good practice to have the NPSHA (available) 3 to 5 psi greater than the NPSHR. This will prevent release of vapor and entrained gases into the suction system, which will cause cavitation damage in the internal passages.
- Figure 76 illustrates the NPSHR for a triplex pump as a function of rotating speed and plunger diameter.



**FIGURE 76. NPSHR for a Triplex Pump**

Reproduced with permission of McGraw-Hill from Karassik, I. J. (ed).  
*Pump Handbook*, 2nd ed., 1986.

### *Net Positive Suction Head Available (NPSHA)*

- The NPSHA is the static head plus the atmospheric head minus lift loss, frictional loss, vapor pressure, velocity head, and acceleration loss in feet available at the suction centerline.

## RECIPROCATING PUMP APPLICATIONS

- Some reciprocating power pump applications are:
  - ammonia service
  - carbamate service
  - chemicals
  - crude-oil pipeline
  - cryogenic service
  - fertilizer plants
  - high-pressure water cutting
  - hydro forming
  - hydrostatic testing
  - liquid petroleum gas
  - liquid pipeline
  - power oil
  - power press
  - soft-water injection for water flood
  - slurry pipeline (70% by weight)
  - slush ash service
  - steel-mill descaling
  - water-blast service
- The following applications should be reviewed with the

pump supplier prior to implementation:

- cryogenic service
- highly compressible liquids
- liquids over 250°F
- liquids with high percentage of entrained gas
- low-speed operation
- slurry pipeline
- special fluid end materials
- viscosity over 250 SSU

# TIPS:

## *Installation, Operation, and Troubleshooting of Pumps*

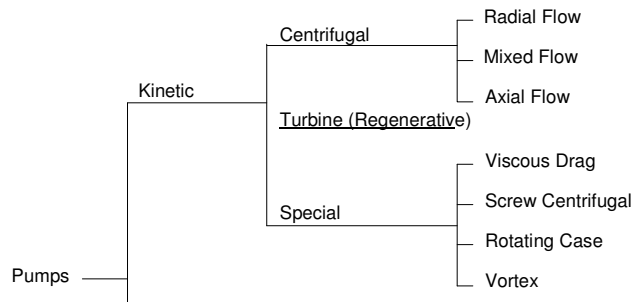
- The subsequent data will provide useful to personnel involved in the application or maintenance of pumps. The information is categorized into the following headings:
  - Alignment of Shafts
  - Water Hammer
  - Minimum Flow Limitation in Centrifugal Pumps
  - Troubleshooting Pump Problems

### ALIGNMENT OF SHAFTS

- Misalignment of the pump and driver shaft can be angular (shaft axes concentric but not parallel), parallel (shaft axes parallel but not concentric), or a combination of both (Figure 77).

#### COUPLINGS

- Couplings provide a mechanically flexible connection for two shaft ends that are in line.
- Couplings also provide limited shaft end float (for mechanical movement or thermal expansion) and within specified limits, angular and parallel misalignment of shafts.



**FIGURE 77. Types of Misalignment**

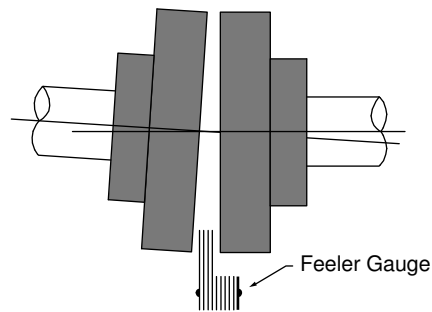
Reproduced with permission of the Hydraulic Institute from *Standards for Centrifugal, Rotary and Reciprocating Pumps*, 14th ed., 1983.

- Couplings are not intended to compensate for major angular or parallel misalignment.
- The allowable misalignment will vary with the type of coupling, and reference should be made to the manufacturer's specifications enclosed with the coupling. Any improvement in alignment over the coupling-manufacturer's minimum specification will increase pump, coupling, and prime mover life by reducing bearing loads and wear.
- Flexible couplings in common use today are chain, gear, steel grid, and flex member.

#### *Angular Misalignment*

- To check angular misalignment as shown in Figure 78
  - insert a feeler gauge between the coupling halves to check the gap;

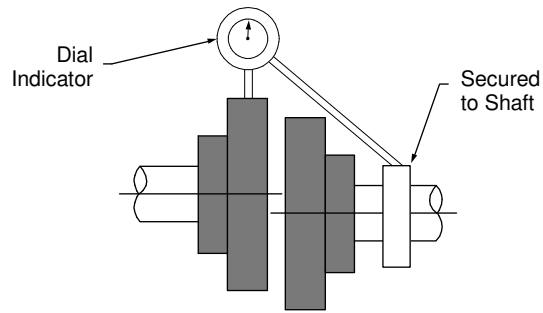
- rotate both halves simultaneously 1/4 turn, 1/2 turn, and then 3/4 turn;
  - check the gap between coupling halves at the same location on the coupling as for the original gap check.
- **Note:** Checking the difference in gap between the coupling without turning both coupling halves can result in error because the coupling halves are at times unmachined and not square with the centerline of the shaft. The variation in gap should not exceed the coupling manufacturer's recommendations.
  - To correct angular misalignment, adjust the amount of shims under the driver and/or adjust driver location in the horizontal plane.



**FIGURE 78. Checking Angular Misalignment**

Reproduced with permission of the Hydraulic Institute from *Standards for Centrifugal, Rotary and Reciprocating Pumps*, 14th ed., 1983.



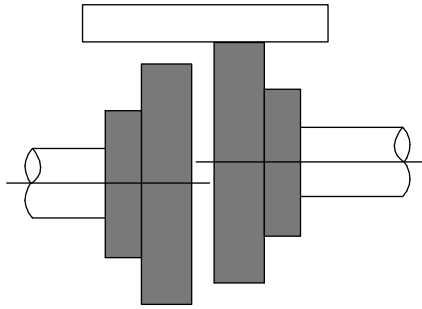


**FIGURE 79. Dial Indicator Method of Checking Parallel Alignment**

Reproduced with permission of the Hydraulic Institute from *Standards for Centrifugal, Rotary and Reciprocating Pumps*, 14th ed., 1983.

*Parallel Misalignment*

- To check parallel misalignment, the dial indicator method shown in Figure 79 is preferred.
  - with the dial indicator attached to the pump or driver shaft, rotate both shafts simultaneously, and record dial indicator readings through one complete revolution;
  - correct the parallel misalignment by adjusting shims under the driver.
- **Note:** Only when absolutely necessary should shims be adjusted or added under the pump. When a dial indicator is not available, an alternate method for checking parallelism is the straight-edge method shown in Figure 80.
- On certain large units, limited end float couplings are used. The instruction manual furnished with such units should be



**FIGURE 80. Straight-Edge Method of Checking Parallel Alignment**

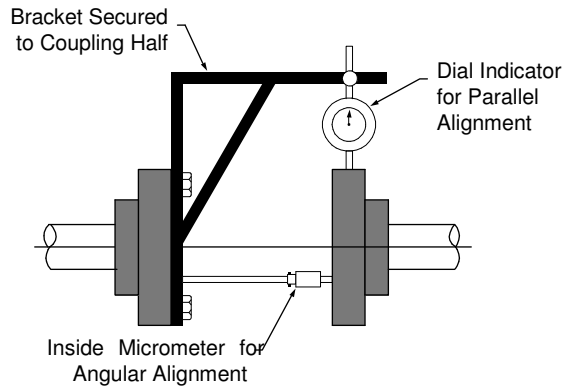
Reproduced with permission of the Hydraulic Institute from *Standards for Centrifugal, Rotary and Reciprocating Pumps*, 14th ed., 1983.

consulted for special alignment instructions that apply to such couplings.

- Spacer-type couplings can be checked for angular and parallel misalignment by the above methods after the spacer has been removed. Because of the distance between the coupling halves, minor changes in the procedure are required:
  - for the angular misalignment check, an inside micrometer replaces the feeler gauge;
  - for the parallel misalignment check, a bracket is attached to one coupling half for mounting of the dial indicator. The adjusted method is illustrated in Figure 81.

#### BELTS AND SHEAVES

- All drives must be aligned. The driver and driven shafts must be parallel, the V-belts at right angles to these shafts.



**FIGURE 81. Method of Checking Alignment on a Spacer Coupling**

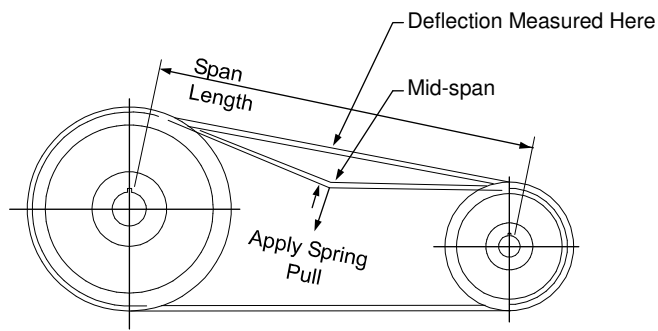
Reproduced with permission of the Hydraulic Institute from *Standards for Centrifugal, Rotary and Reciprocating Pumps*, 14th ed., 1983.

Misalignment will cause undue belt wear, or turn over in the grooves. Check alignment by placing a straight edge evenly across the rims of both sheaves. If the faces of the sheaves are not of equal width, the alignment can be checked by resting the straight edge across the rim of the widest sheave and measuring the distance from the straight edge to the nearest belt groove with a scale. Adjust either sheave on the shaft to equalize these dimensions.

- The driver should be mounted with adequate provision for belt center distance adjustment. Provide a minus adjustment to permit belt installation without stretching and a plus allowance to provide belt take-up.
- Do not force the belts over the sheave grooves. This will damage the belts and greatly reduce the belt life. Reduce

the shaft center distance by moving the driver enough to permit fitting the belts in the proper grooves. When the belts are in place, increase the centers until proper belt tension is obtained. Adjust take-up until only a slight bow appears on the slack side. All of the belts must be pulling evenly. Belt tension should be reasonable; it is not necessary to have belts “fiddle-string” tight. Multi-groove belts can be ordered as “matched sets” to assist with belt tension.

- For hazardous locations, static conducting belts should be used.
- Consult V-belt manufacturer’s tables and data for recommended V-belt cross-sections and belt length. When purchasing replacement V-belts, the same size and type should be reordered.
- Slipping belts will result in lowered capacity. Check pump speed with tachometer. Squealing or smoking belts are sometimes a clue to the slipping of belts.



**FIGURE 82. Correct Tension Check for V-belt Drives**

- Establishing correct tension in single or multiple V-belt drives requires the use of a small spring scale, applied at the center of the belt span (Figure 82). Apply spring pressure to produce the belt deflections shown in Table 3. Then read the scale and tighten or loosen as needed.

**TABLE 3. Proper Spring Pull Tension for New and Used Belts**

Belt Size Section	Force For Normal Tension, Pounds	Force for New Belts, Pounds	Approximate Belt Span in Inches							
			20	24	28	32	40	48	60	
A	1.5 to 2.25	2.25 to 3.0								
B	3.25 to 5.0	5.0 to 6.0								
C	6.5 to 9.75	9.75 to 13								
D	11 to 16.5	16.5 to 22								
3V	3.0 to 7.5	4.0 to 10	5/16 Deflection	3/8 Deflection	7/16 Deflection	1/2 Deflection	5/8 Deflection	3/4 Deflection		
5V	13 to 23	17 to 30								
8V	22 to 29	29 to 35								15/16 Deflection

## WATER HAMMER

- Water hammer is an increase in pressure due to rapid changes in the velocity of a liquid flowing through a pipe line. This dynamic pressure change is the result of the transformation of the kinetic energy of the moving mass of liquid into pressure energy. When the velocity is changed by closing a valve or by some other means, the magnitude of the pressure produced is frequently much greater than the static pressure on the line, and may cause rupture or damage to the pump, piping, or fittings. This applies both to horizontal and vertical pump installations.

- Starting at the closed valve, a wave of increased pressure is transmitted back through the pipe with constant velocity and intensity. When the pressure wave has travelled upstream to the end of the pipe where there is a reservoir or large main, the elasticity of the compressed liquid and of the expanded pipe reverse the flow. A wave of normal pressure then travels downstream with the flow being progressively reversed as the liquid expands.
- If the liquid were incompressible and the pipe inelastic, the instantaneous closure of the valve would create an infinite pressure. Since it is impossible to close a valve instantaneously, a series of pressure waves is created, which causes an increased pressure at the valve. If the valve is completely closed before the first pressure wave has time to return to the valve as a wave of low pressure, the pressure increases continuously up to the time of complete closure. The resulting pressure is the same as if the valve had been closed instantaneously.
- The velocity of the pressure wave depends upon the ratio of the wall thickness to the inside pipe diameter, on the modulus of elasticity of the pipe material, and on the modulus of elasticity of the liquid.
- The head due to water hammer in excess of normal static head is a function of the destroyed velocity, the time of closure, and the velocity of pressure wave along the pipe.
- Water hammer may be controlled by regulating valve closure time, relief valves, surge chambers, and other means.

## MINIMUM FLOW LIMITATION IN CENTRIFUGAL PUMPS

- All centrifugal pumps have limitations on the minimum flow at which they should be operated. The most common is to avoid excessive temperature buildup in the pump because of absorption of the input power into the pumped fluid. Other reasons for restrictions are as follows:
  - increased radial reaction at low flows;
  - increased NPSHR at low flows resulting in cavitation;
  - noisy, rough operation and possible physical damage due to internal recirculation;
  - increased suction and discharge pulsation levels;
  - increased axial reaction affecting thrust-bearing loading.
- The size of the pump, the energy absorbed, and the liquid pumped are among considerations in determining these minimum limitations.
- **For example:** Most small pumps on ordinary applications with good suction conditions, such as domestic home circulators, service water pumps, and chemical pumps, have no limitations except for temperature buildup considerations.
- For small pumps, when NPSH is critical, limitations of about 25% of the capacity at the best efficiency point should be imposed. Many large, high horsepower pumps have limitations as high as 70% of the best efficiency capacity.
- The manufacturer should be consulted in all cases where doubt exists regarding the allowable minimum flow.

# TROUBLESHOOTING PUMP PROBLEMS

## CENTRIFUGAL PUMP

- When investigating pump trouble at the job site, every effort must first be made to eliminate all outside influences. If the performance is suspect, the correct use and accuracy of instruments should first be checked. Pump performance is substantially affected by such liquid characteristics as temperature, specific gravity, and viscosity.

### *No Discharge*

- Lack of discharge from a pump may be caused by any of the following conditions:
  - pump not primed
  - speed too low
  - system head too high
  - suction lift higher than that for which pump is designed
  - impeller completely plugged
  - impeller installed backwards
  - wrong direction of rotation
  - air leak in the suction line
  - air leak through the stuffing box
  - well draw-down below minimum submergence
  - pump damaged during installation (wells)
  - broken line shaft or coupling
  - impeller(s) loose on shaft
  - closed suction valve



### *Insufficient Discharge*

- Insufficient discharge from a pump may be caused by any of the following conditions:
  - partial air blockage suction or casing
  - air leaks in suction or stuffing boxes
  - speed too low
  - system head higher than anticipated
  - insufficient NPSHA
  - impeller partially plugged
  - mechanical defects (wearing rings worn, impeller damaged)
  - impeller(s) loose on shaft
  - excessive lift on rotor element
  - suction or discharge valve(s) partially closed
  - leaking joints (well application)
  - foot valve of suction opening not submerged enough
  - impeller installed backwards
  - wrong direction rotation

### *Insufficient Pressure*

- Insufficient pressure from a pump may be caused by any of the following conditions:
  - speed too low
  - system head less than anticipated
  - air or gas in liquid
  - mechanical defects: wearing rings worn; impeller damaged
  - impeller diameter too small
  - impeller installed backwards

- wrong direction of rotation
- excessive lift on rotor element
- leaking joints (well application)

*Vibration and Noise*

- coupling misalignment
- unstable foundation
- foreign material in pump causing imbalance
- bearings starting to fail
- bent shaft
- damaged components: impeller, shaft, packing, coupling
- suction lift too high
- pump over or under rated capacity
- loose components, valves, guards, brackets

*Loss of Suction Following Period of Satisfactory Operation*

- Loss of suction following period of satisfactory operation may be caused by any of the following conditions:
  - leaky suction line
  - waterseal plugged
  - suction lift too high or insufficient NPSHA
  - air or gas in liquid
  - casing gasket defective
  - clogging of strainer
  - excessive well draw-down

### *Excessive Power Consumption*

- Excessive power consumption may be caused by any of the following conditions:
  - speed too high
  - system head lower than rating, pumps too much liquid (radial and mixed-flow pumps)
  - system head higher than rating, pumps too little liquid (axial-flow pumps)
  - specific gravity or viscosity of liquid pumped is too high
  - mechanical defects (shaft bent, rotating element binds), stuffing boxes too tight, wearing rings worn)
  - electrical or mechanical defect in submerged motor
  - undersized submersible cable
  - incorrect lubrication of driver
  - lubricant in shaft enclosing tube too heavy (vertical turbine)

### ROTARY PUMP

- The causes of a majority of pump or system malfunctions can be detected by determination of inlet and outlet conditions. For this purpose, install a vacuum or compound gauge near the pump inlet and a pressure gauge near the pump outlet.
- Predominant malfunctions and their causes are given below.

### *No Fluid Discharged*

- pump not primed
- wrong direction of rotation
- valves closed or obstruction in inlet or outlet line
- end of inlet pipe not submerged in fluid

- foot valve stuck
- net inlet pressure too low
- bypass valve open
- air leak in inlet line
- strainer clogged
- pump badly worn
- loose coupling, broken shaft, failed pump

*Low Discharge Rate*

- net inlet pressure too low
- strainer partially clogged or of insufficient area
- air leak in inlet line
- air leak through packing
- end of inlet line not sufficiently submerged causing eddies and air entry to pump
- starving or cavitating
- bypass valve partially open
- speed too low, motor may be wired improperly or overloaded
- pump worn

*Loss of Prime (After Satisfactory Operation)*

- fluid supply exhausted
- substantial increase in fluid viscosity
- fluid vaporizes in inlet line, fluid may be overheated
- air leaks developed in suction line

### *Excessive Power Consumption*

- pump running too fast
- higher fluid viscosity than specified
- discharge pressure higher than calculated
- improperly adjusted packing gland (too tight) causing drag on shaft
- rotating element binding from misalignment
- where required, the extra clearances on rotating elements are insufficient for the fluid viscosity

### *Excessive Noise Vibration*

- pump cavitation due to vaporization in inlet line
- pump starved on high viscosity fluid
- misalignment conditions
- relief valve chatter
- foundation and/or hold-down bolts loose
- bearings failing
- piping inadequately supported

### *Rapid Pump Water*

- abrasives in fluid
- corrosion of pump elements
- misalignment conditions
- pump runs dry, pump stalls due to frictional heat generated
- lack of lubrication
- high discharge pressure

## RECIPROCATING PUMP

### *Pump Fails to Deliver Required Capacity*

- speed incorrect, belts slipping
- air leaking into pump
- liquid cylinder valves, seats, piston packing, liner, rods or plungers worn
- insufficient NPSHA
- pump not filling
- makeup in suction tank less than displacement of pump
- capacity of booster pump less than displacement of power pump
- vortex in supply tank
- one or more cylinders not pumping
- suction lift too great
- broken valve springs
- stuck foot valve
- pump valve stuck open
- clogged suction strainer
- relief, bypass, pressure valves leaking
- internal bypass in liquid cylinder

### *Suction and/or Discharge Piping Vibrates or Pounds*

- piping too small and/or too long
- worn valves or seats
- piping inadequately supported

### *Pump Vibrates or Pounds*

- gas in liquid

- pump valve stuck open
- pump not filling
- one or more cylinders not pumping
- excessive pump speed
- worn valves or seats
- broken valve springs
- loose piston or rod
- unloader pump not in synchronism
- loose or worn bearings
- worn crossheads or guides
- loose crosshead pin or crank pin; loose pull or side rods or connecting rod cap bolts
- pump running backwards
- water in power end crankcase
- worn or noisy gear

*Consistent Knock*

- worn or loose main bearing, crank pin bearing, wrist pin bushing, plunger, valve seat, low oil level
- **Note:** High speed power pumps are not quiet. Check only when the sound is erratic.

*Packing Failure (Excessive)*

- improper installation
- improper or inadequate lubrication
- packing too tight
- improper packing selection
- scored plungers or rods

- worn or oversized stuffing box bushings
- plunger or rod misalignment

#### *Wear of Liquid End Parts*

- abrasive or corrosive action of the liquid
- incorrect material

#### *Liquid End Cylinder Failure*

- air entering suction system
- incorrect material
- flaws in casting or forging

#### *Wear of Power End Parts (Excessive)*

- poor lubrication
- overloading
- liquid in power end

#### *Excessive Heat in Power End (Above 180°C)*

- pump operating backwards
- insufficient oil in power end
- excessive oil in power end
- incorrect oil viscosity
- overloading
- tight main bearings
- driver misaligned
- belts too tight
- discharge valve of a cylinder(s) stuck open
- insufficient cooling
- pump speed too low



## CONVERSION FACTORS

**Table A. Unit Conversion**

Inch/Pound (IP) to Metric (SI)		SI to IP	
<b>length</b>			
1 in	25.400 mm	1 mm	0.03937 in
1 ft	0.304 80 m	1 m	3.2808 ft
<b>area</b>			
1 in <sup>2</sup>	645.16 mm <sup>2</sup>	1 mm <sup>2</sup>	0.001 55 in <sup>2</sup>
1 ft <sup>2</sup>	0.092 903 m <sup>2</sup>	1 m <sup>2</sup>	10.764 ft <sup>2</sup>
<b>mass</b>			
1 lb <sub>m</sub>	0.453 59 kg	1 kg	2.2046 lb <sub>m</sub>
<b>volume</b>			
1 ft <sup>3</sup>	0.028 317 m <sup>3</sup>	1 m <sup>3</sup>	35.315 ft <sup>3</sup>
1 ft <sup>3</sup>	28.317 L	1 L	0.035 315 ft <sup>3</sup>
1 gal Imp	4.546 1 L	1 L	0.219 97 gal Imp
1 gal US	3.785 4 L	1 L	0.264 17 gal US
<b>density</b>			
1 lb <sub>m</sub> /ft <sup>3</sup>	16.018 kg/m <sup>3</sup>	1 kg/m <sup>3</sup>	0.062 430 lb <sub>m</sub> /ft <sup>3</sup>
<b>specific n</b>			
1 ft <sup>3</sup> /lb <sub>m</sub>	0.062 43 m <sup>3</sup> /kg	1 m <sup>3</sup> /kg	16.018 ft <sup>3</sup> /lb
<b>velocity</b>			
1 fps	0.304 80 m/s	1 m/s	3.280 8 fps
1 fpm	0.005 0800 m/s	1 m/s	196.85 fpm

**Table A. Unit Conversion (cont'd.)**

Inch/Pound (IP) to Metric (SI)		SI to IP	
<b>force</b>			
1 lbf	4.448 2 N	1 N	0.224 81 lbf
<b>torque</b>			
1 lbf·ft	1.355 8 N·m	1 N·m	0.737 56 lbf·ft
<b>flow rate</b>			
1 cfs	28.317 L/s	1 L/s	0.03531 cfs
1 cfm	0.471 95 L/s	1 L/s	2.118 9 cfm
1 gpm (Imp)	0.075 77 L/s	1 L/s	13.198 gpm (Imp)
1 gpm (US)	0.063 09 L/s	1 L/s	15.850 gpm (US)
<b>pressure</b>			
1 psi	6.894 kPa	1 kPa	0.145 03 psi
1 psf	0.047 88 kPa	1 kPa	20.885 psf
1 ft. wg <sup>(1)</sup>	2.986 1 kPa	1 kPa	0.334 88 ft. wg <sup>(1)</sup>
1 in. wg <sup>(1)</sup>	0.24884 Pa	1 kPa	4.018 6 in. wg <sup>(1)</sup>
1 in. Hg <sup>(1)</sup>	3.3769 kPa	1 kPa	0.296 12 in. Hg <sup>(1)</sup>
<b>energy, work</b>			
1 Btu	1.055 1 kJ	1 kJ	0.947 85 Btu
1 kW·h	3.60 J	1 J	0.277 78 kW·h
1 ft·lbf	1.3558 J	1 J	0.737 56 ft·lbf
<b>power</b>			
1 Btu/h	0.293 07 W	1 kW	3.4122 MBh <sup>(2)</sup>
1 hp (electric)	746.00 W	1 kW	1.3405 hp (electric)
1 hp (mech)	745.70 W	1 kW	1.3410 hp (550 ft·lbf/s)

**Notes:**

<sup>1</sup> Water and mercury at 20°C (68°F)

<sup>2</sup> M = 10<sup>3</sup> in Mbh

**TABLE B. Temperature Conversions**

To Convert from	to	Multiply by
deg. Fahrenheit (°F)	deg. Celsius (°C)	$T_{°C} = (t_F - 32)/1.8$
deg. Fahrenheit (°F)	deg. Rankine (°R) or $F_{(abs)}$	$T_{(°R)} = t_F + 459.67$
deg. Fahrenheit (°F)	deg. Kelvin (°K)	$T_{(°K)} = (t_F + 459.67)/1.8$
deg. Rankine (°R) or $F_{(abs)}$	deg. Kelvin (°K)	$T_{(°K)} = T_{°R}/1.8$
deg. Celsius (°C)	deg. Kelvin (°K)	$T_{(°K)} = T_{°C} + 273.15$
deg. Kelvin (°K)	deg. Celsius (°C)	$t_{(°C)} = T_{°K} - 273.15$

## GLOSSARY OF TERMS

### NET POSITIVE SUCTION HEAD AVAILABLE (NPSHA)

- Available NPSH is a characteristic of the pumping system. It is defined as the energy that is in a liquid at the suction connection of the pump.

### BERNOULLI'S THEOREM

- Energy cannot be created or destroyed. The sum of three types of energy (heads) at any point in a system is the same in any other point in the system assuming no frictional losses or the performance of extra work.

### BRAKE HORSEPOWER

- Brake horsepower is the total power required by the pump to do a specified amount of work.

### CAPACITY

- Capacity is actual pump delivery. Capacity is equal to displacement minus slip.

### CAVITATION

- Cavitation occurs when pressure in the suction line falls below vapor pressure, vapor is formed and moves along with the stream. These vapor bubbles or cavities collapse when they reach regions of higher pressure on their way through the pump. The most obvious effects of cavitation are noise and vibration.

#### DENSITY

- Density, sometimes referred to as specific weight, is the weight per unit volume of a particular substance. The density of water is 62.4 pounds per cubic foot (lbs/ft<sup>3</sup>) at sea level and 60°F.

#### DISPLACEMENT

- Displacement is the theoretical delivery of the pump expressed in gallons per minute.

#### FLOW Q

- The rate of flow is normally expressed in U.S. gallons per minute (gpm US), cubic feet per second (cfs), or million U.S. gallons per 24-hour day (mgd).

#### HEAD (H)

- Head is a quantity used to express a form or combinations of forms of the energy content of the liquid per unit weight of the liquid referred to in any arbitrary datum in terms of foot-pounds of energy per pound of liquid. All head quantities have the dimensions of feet of liquid. The relationship between a pressure expressed in pounds per square inch (lbs/in<sup>2</sup>) and that expressed in feet of head is as follows:

$$h(\text{feet}) = \frac{\text{lbs}}{\text{in}^2} \times \frac{2.31}{W}$$

where:

W = specific weight of liquid being pumped under pumping conditions in pounds per cubic foot (lbs/ft<sup>3</sup>)

Sq.gr. = specific gravity of liquid pumped

- A liquid may have three kinds of energy (heads), or the capacity to do work may be due to three factors:
  - *potential head (energy of position)* - measured by work possible in dropping vertical distance;
  - *static pressure head (energy per pound due to pressure)* - the height to which liquid can be raised by a given pressure;
  - *velocity head (kinetic energy per pound)* - the vertical distance a liquid would have to fall to acquire the velocity "V".

#### HYDRAULIC HORSEPOWER

- Hydraulic horsepower (water horsepower) is the power required by the pump for pumping only.

#### MECHANICAL EFFICIENCY (EM)

- Mechanical efficiency is the ratio of power output to power input.

$$E_m = \frac{\text{output horsepower}}{\text{input horsepower}}$$

$$E_m = \frac{\text{water horsepower}}{\text{brake horsepower}} \quad \text{(common for reciprocating pumps)}$$

$$E_m = \frac{\text{whp}}{3960 \times \text{brake horsepower}} \quad \text{(common for reciprocating pumps)}$$

#### NET DISCHARGE HEAD

- Net discharge head is the sum of static discharge head and discharge frictional losses.

#### NET POSITIVE SUCTION HEAD (NPSH)

- NPSH is the amount of energy in the liquid at the pump datum.

#### NET SUCTION HEAD

- Net suction can be the following:
  - sum of static suction lift plus frictional losses (net suction lift, which is negative);
  - static suction head minus frictional losses (may be either positive or negative).

#### PIPE FRICTION

- Pipe friction is the resistance offered to the liquid by the piping and fittings as it is being pumped through the system. Friction will vary with pipe size, capacity, length of pipe, viscosity, and number and type of fittings.

#### PRESSURE

- Pressure is the force exerted per unit area of a fluid. It can be considered a compressive stress. The most common unit for designating pressure is pounds per square inch (lbs/in.<sup>2</sup>). According to Pascal's principle, if pressure is applied to the surface of a fluid, this pressure is transmitted undiminished in all directions. There are three designations of pressure: gauge, atmospheric, and absolute.

gauge + atmospheric = absolute

1 atmosphere = 14.7 lbs/in.<sup>2</sup> = 33.96 ft water

$$\frac{\text{lbs in}^2}{\text{Head in feet} \times 2.31} \quad \neq \text{specific gravity}$$





#### NET POSITIVE SUCTION HEAD REQUIRED (NPSHR)

- Required NPSH is the energy needed to fill a pump on the suction side and overcome the frictional and flow losses from the suction connection to that point in the pump at which more energy is added. Required NPSH varies with pump design, pump size, and operating conditions and is supplied by the pump manufacturer.

#### SLIP

- Slip is loss in delivery due to escape of liquid inside the pump from discharge to suction.

#### SPECIFIC GRAVITY

- Specific gravity of a substance is the ratio of its density (or specific weight) to that of some standard substance. For liquids, the standard substance used is water at 60°F. Most pump performance characteristics are determined using water at a specific gravity of 1.0. Therefore, it is extremely important to know the specific gravity of the liquid to be pumped so proper corrections can be made. **Note:** Specific gravity is a dimensionless number.

#### STATIC SUCTION HEAD

- Static suction head occurs when the supply is above the pump.

#### STATIC SUCTION LIFT

- Static suction lift occurs when the source of supply is below the pump. Vertical distance from free surface of the liquid to the pump datum.

#### VAPOR PRESSURE

- The vapor pressure of a liquid at a specified temperature is the pressure at which the liquid is in equilibrium with the atmosphere or with its vapor in a closed container. At pressures below this vapor pressure at a given temperature, the liquid will start to vaporize due to the reduction in pressure at the surface of the liquid. (At 60°F, the vapor pressure of water is 0.256 psi. At 212°F, it is 14.7 psi.)

#### VELOCITY HEAD (HV)

- Velocity head is the kinetic energy per unit weight of the liquid at a given section. It is calculated from the average velocity (V) obtained by dividing the flow in cubic feet per second (ft<sup>3</sup>/s) by the actual internal area of the pipe cross-section in square feet (ft<sup>2</sup>) and determined at the point of gauge connection. Velocity head is expressed by the following formula:

$$hv_{(feet)} = \frac{V^2}{2g}$$

where:

V = velocity in pipe, (ft/s)

g = acceleration due to gravity, 32.17 ft/s<sup>2</sup> at sea level

#### VISCOSITY

- Viscosity is the internal friction of the liquid or that property that resists any force tending to produce flow. Absolute (or dynamic) viscosity is usually expressed in centipoise.
- Kinematic viscosity is the ratio of absolute viscosity to density and is expressed in centistokes (SSU). Viscosity varies

with temperature change, decreasing as the temperature is increased.

- Many liquids such as water and mineral oil are considered Newtonian and do not change in viscosity with a change in rate of shear or agitation. Liquids such as grease, syrups, glues, and varnishes are called Thixotropic. These show a marked reduction in viscosity as the rate of shear is increased. Other liquids such as clay slurries, some starches and paints, and milk chocolate with filler are referred to as Dilatant. They show an increase in viscosity as the rate of shear is increased.
- Viscosity is measured by viscometers such as Saybolt (U.S.), Bedwood (U.K.), and Engler (Germany). They measure the time of flow of a specific quantity of liquid through a small tube with a gravity head. The above instruments measure kinematic viscosity. The Brookfield viscometer utilizes a spinning disk or cylinder (at a known speed) and measures torque and absolute viscosity.

#### VOLUMETRIC EFFICIENCY

- Volumetric efficiency is the ratio of pump capacity to theoretical displacement.



## INDEX

- Bearings, 57, 102
- Belts, 115
- Bernoulli's theorem, 6
- Blow case pump, 26
- Casing, 35
  - Solid casing, 35
  - Split casing, 36
- Centrifugal pumps, 6
  - axial flow, 7
  - mixed flow, 7
  - radial flow, 7
- Centrifugal pump applications, 76
- Couplings, 111
- Curves, 59
  - overall rating curves, 62
- Impellers, 36
  - enclosed impeller, 39
  - open impeller, 37
  - semi-open impeller, 38
- Impeller diameter, 74
- Kinetic pumps, 5
- Mechanical seals, 49
- Mechanical seal types, 51
  - balanced seal, 55
  - double seal, 53
  - single external seal, 52
  - single internal seal, 51
  - unbalanced seal 54
- Open screw pump, 26
- Positive displacement pumps, 15
- Pump rating curves, 59
  - brake horsepower-capacity curve, 60
  - efficiency-capacity curve, 60
  - head-capacity curve, 59
  - net positive suction head (NPSH)-capacity curve, 62
- Pumps, troubleshooting, 121
- Reciprocating pumps, 23
  - diaphragm, 24
  - piston/plunger, 23
- Reciprocating pump applications, 108
- Rotary pumps, 15
  - circumferential piston pump, 20
  - flexible member pump, 17
  - gear pump, 18
  - lobe pump, 18
  - piston pump, 16
  - screw pump, 21
  - vane pump, 16

Rotary pump applications, 91	Stuffing box, 49, 99
Rotating casing pump, 13	Turbine pumps
Screw centrifugal pump, 11	(regenerative), 9
Shafts, 46	Viscous drag or disk pump, 10
Shaft alignment, 111	Volute, 6
Shaft sleeves, 47	Vortex pump, 13
Sheaves, 115	Water hammer, 118
Specific speed, 42	Wearing rings, 44



